

TECHNICAL MANUAL

OPERATOR, ORGANIZATIONAL AND DIRECT
SUPPORT MAINTENANCE MANUAL

DETECTING SET, MINE: AURAL INDICATION;
10V DC OPERATING POWER: PORTABLE
TRANSISTORIZED, W/CASE AN/PSS-11

(POLAN MODELS P153 AND P158) FSN 6665-966-9071

(POLAN MODEL P190) FSN 6665-181-0432

(OREGON TECHNICAL PRODUCTS MODEL MD-M)

FSN 6665-966-0972

(THE VP COMPANY MODEL VP200) FSN 6665-144-7655

(FOURDEE MODEL 4D5000) FSN 6665-181-0369

HEADQUARTERS, DEPARTMENT OF THE ARMY

27 DECEMBER 1971

CHANGE

NO. 4

HEADQUARTERS
DEPARTMENT OF THE ARMY
WASHINGTON, D.C., 31 October 1994Operator, Organizational and Direct Support
Maintenance Manual

**DETECTING SET, MINE: AURAL INDICATION;
10 V DC OPERATING POWER; PORTABLE
TRANSISTORIZED, W/CASE AN/PSS-11
(POLAN MODELS P153 AND P158) NSN 6665-00-966-9071
(POLAN MODEL P190) NSN 6665-00-181-0432
(OREGON TECHNICAL PRODUCTS MODEL MD-M)
NSN 6665-00-966-9072
(THE VP COMPANY MODEL VP200) NSN 6665-00-144-7655
FOURDEE MODEL 4D5000) NSN 6665-00-181-0369**

DISTRIBUTION STATEMENT A: Approved for public release; distribution is unlimited

TM 5-6665-202-13, 27 December 1971, is changed as follows:

1. Remove and insert pages as indicated below. New or changed text material is indicated by a vertical bar in the margin. An illustration change is indicated by a miniature pointing hand.

Remove pages

2-1 and 2-2

6-9 and 6-10

Insert pages

2-1 and 2-2

6-9 and 6-10

2. Retain this sheet in front of manual for reference purposes.

By Order of the Secretary of the Army:

Official:

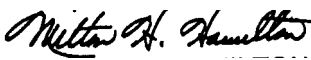
MILTON H. HAMILTON
Administrative Assistant to the
Secretary of the Army

07679

GORDON R. SULLIVAN
General, United States Army
Chief of Staff

DISTRIBUTION:

To be distributed in accordance with DA Form 12-25-E, block no. 0619, requirements for
TM 5-6665-202-13.

CHANGE

HEADQUARTERS

NO. 3

DEPARTMENT OF THE ARMY
WASHINGTON, D.C., 28 February 1994Operator, Organizational and Direct Support
Maintenance Manual

DETECTING SET, MINE: AURAL INDICATION;
10 V DC OPERATING POWER; PORTABLE
TRANSISTORIZED, W/CASE AN/PSS-11
(POLAN MODELS P153 and P158) NSN 6665-00-966-9071
(POLAN MODEL P190) NSN 6665-00-181-0432
(OREGON TECHNICAL PRODUCTS MODEL MD-M)
NSN 6665-00-966-9072
(THE VP COMPANY MODEL VP200) NSN 6665-00-144-7655
FOURDEE MODEL 4D5000) NSN 6665-00-181-0369

DISTRIBUTION STATEMENT A: Approved for public release; distribution is unlimited.

TM 5-6665-202-13, 27 December 1971, is changed as follows:

1. Remove and insert pages as indicated below. New or changed text material is indicated by a vertical bar in the margin. An illustration change is indicated by a miniature pointing hand.

Remove pages

i and ii
2-3 through 2-10
4-1 and 4-2

Insert pages

i and ii
2-3 through 2-10
4-1 and 4-2

2. Retain this sheet in front of manual for reference purposes.

By Order of the Secretary of the Army:

GORDON R. SULLIVAN
General, United States Army
Chief of Staff

Official:

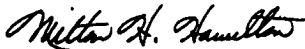
MILTON H. HAMILTON
Administrative Assistant to the
Secretary of the Army

06252

DISTRIBUTION:

To be distributed in accordance with DA Form 12-25-E, block no. 0619, requirements for TM 5-6665-202-13.

CHANGE

NO. 2

HEADQUARTERS
DEPARTMENT OF THE ARMY
WASHINGTON, D.C., 22 April 1991

Operator, Organizational and Direct Support
Maintenance Manual

**DETECTING SET, MINE: AURAL INDICATION;
10 V DC OPERATING POWER; PORTABLE
TRANSISTORIZED, W/CASE AN/PSS-11
(POLAN MODELS P153 AND P158) NSN 6665-00-966-9071
(POLAN MODEL P190) NSN 6665-00-181-0432
(OREGON TECHNICAL PRODUCTS MODEL MD-M)
NSN 6665-00-966-9072
(THE VP COMPANY MODEL VP200) NSN 6665-00-144-7655
(FOURDEE MODEL 4D5000) NSN 6665-00-181-0369**

Approved for public release; distribution is unlimited

TM 5-6665-202-13, 27 December 1971, is changed as follows:

1. Remove and insert pages as indicated below. New or changed text material is indicated by a vertical bar in the margin. An illustration change is indicated by a miniature pointing hand.

Remove pages	Insert pages
---	a/(b blank)
i and ii	i and ii
1-1 and 1-2	1-1 and 1-2
2-1 through 2-9/(2-10 blank)	2-1 through 2-10
5-1 through 5-7	5-1 through 5-8
6-5 and 6-6	6-5 and 6-6
B-1 and B-2	B-1 and B-2
C-3/(C-4 blank)	C-3/(C-4 blank)

2. Retain this sheet in front of manual for reference purposes.

By Order of the Secretary of the Army:

CARL E. VUONO
General, United States Army
Chief of Staff

Official:

THOMAS F. SIKORA
Brigadier General, United States Army
The Adjutant General

DISTRIBUTION:

To be distributed in accordance with DA Form 12-25E, (qty rqr block no. 0619)

Change

No. 1

HEADQUARTERS
DEPARTMENT OF THE ARMY
Washington, D.C., 20 October 1978

Operator, Organizational and Direct
Support Maintenance Manual

DETECTING SET, MINE: AURAL INDICATION;
10V DC OPERATING POWER; PORTABLE
TRANSISTORIZED, W/CASE AN/PSS-11
(POLAN MODELS P153 AND P158) NSN 6665-00-966-9071
(POLAN MODEL P190) NSN 6665-00-181-0432
(OREGON TECHNICAL PRODUCTS MODEL MD-M)
NSN 6665-00-966-9072
(THE VP COMPANY MODEL VP200) NSN 6665-00-144-7655
(FOURDEE MODEL 4D5000) NSN 6665-00-181-0369

TM 5-6665-202-13, 27 December 1971, is changed as follows:

1. Title is changed as shown above.
2. Remove and insert pages as indicated below:

Remove

i and ii
1-1 and 1-2
2-7 and 2-8
2-9
3-1 and 3-2
4-1 and 4-2
6-3 and 6-4
A-1
B-1 through B-3

I-1 and I-2

Insert

i and ii
1-1 and 1-2
2-7 and 2-8
2-9
3-1 and 3-2
4-1 and 4-2
6-3 and 6-4
A-1
B-1 and B-2
C-1 through C-3
I-1 and I-2

3. New or changed text material is indicated by a vertical bar in the margin.
An illustration change is indicated by a miniature pointing hand.

4. Retain this sheet in front of the manual for reference purposes.

By Order of the Secretary of the Army:

Official:

BERNARD W. ROGERS
General, United States Army
Chief of Staff

J. C. PENNINGTON
Brigadier General, United States Army
The Adjutant General

DISTRIBUTION:

To be distributed in accordance with DA Form 12-25A, Line A-40, Operator's Maintenance Requirements for Land Mine Detection.

WARNING

DEATH

or severe injury

may occur to operator if safety precautions are not observed while searching suspected mined areas.

Do not operate the mine detector set if it is improperly adjusted. Cease searching suspected mined areas immediately if faulty signal responses or other indications of improper operation are detected.

Be extremely careful when searching an area that is covered with metal fragments, as there is danger of encountering mines yielding signals that might be mistaken for those caused by the metal fragments.

False signals, sufficient to override the signals normally obtained when small pieces of metal are encountered, may sometimes be produced during search operations in a rain or heavy dew, or when the detector head comes in contact with wet grass, weeds, or foliage.

WARNING**DEATH**

or severe injury

may occur to operator if safety precautions are not observed while searching suspected mined areas.

Do not operate the mine detector set if it is improperly adjusted. Cease searching suspected mined areas immediately if faulty signal responses or other indications of improper operation are detected.

Be extremely careful when searching an area that is covered with metal fragments, as there is danger of encountering mines yielding signals that might be mistaken for those caused by the metal fragments.

False signals, sufficient to override the signals normally obtained when small pieces of metal are encountered, may sometimes be produced during search operations in a rain or heavy dew, or when the detector head comes in contact with wet grass, weeds or foliage.

Do not operate detector unless yellow with black stripe output amplifier module is installed. Output amplifier modules other than the yellow with black stripe may not alert the operator of low battery voltage. Detectors operated with low battery voltage will not detect metallic objects, which endangers the life of the operator.

Do not operate the mine detector set prior to performing preliminary adjustment and sensitivity check. Faulty signal responses or other indications of improper operation endanger the life of the operator.

**Operator, Organizational and Direct
Support Maintenance Manual**

**DETECTING SET, MINE: AURAL INDICATION;
10V DC OPERATING POWER; PORTABLE
TRANSISTORIZED, W/CASE AN /PSS-11
(POLAN MODELS P153 AND P158) NSN 6665-00-966-9071
(POLAN MODEL P190) NSN 6665-00-181-0432
(OREGON TECHNICAL PRODUCTS MODEL MD-M)
NSN 6665-00-966-9072
(THE VP COMPANY MODEL VP200) NSN 6665-00-144-7655
(FOURDEE MODEL 4D5000) NSN 6665-00-181-0369**

REPORTING ERRORS AND RECOMMENDING IMPROVEMENTS

You can help improve this manual. If you find any mistakes or if you know of a way to improve the procedures, please let us know. Mail your letter, DA Form 2028 (Recommended Changes to Publications and Blank Forms), or DA Form 2028-2 located in back of this manual direct to: Commander, US Army Aviation and Troop Command, ATTN: AMSAT-I-MP, 4300 Goodfellow Blvd., St. Louis, MO 631 20-1 798. A reply will be furnished to you.

		Paragraph	Page
CHAPTER 1.	INTRODUCTION		
Section I.	General	1-1	1-1
II.	Description and Data	1-5	1-1
CHAPTER 2.	OPERATING INSTRUCTIONS		
Section I.	Service upon receipt of materiel	2-1	2-1
II.	Movement to a new worksite	2-3	2-2
III.	Controls and instruments	2-5	2-3
IV.	Operation under usual conditions	2-7	2-3
V.	Operation under unusual conditions	2-11	2-9
CHAPTER 3.	OPERATOR/CREW MAINTENANCE INSTRUCTIONS		
Section I.	Lubrication instructions		3-1
II.	Preventive maintenance checks and services	3-1	3-1
III.	Troubleshooting	3-3	3-2
IV.	Maintenance of the mine detecting set	3-5	3-2
CHAPTER 4.	ORGANIZATIONAL MAINTENANCE INSTRUCTIONS		
Section I.	Service upon receipt of material	4-1	4-1
II.	Movement to a new worksite		4-1
III.	Repair parts, special tools, and equipment	4-3	4-1
IV.	Lubrication instructions		4-1
V.	Preventive maintenance checks and services	4-5	4-1
VI.	Troubleshooting	4-7	4-2
VII.	Maintenance of the mine detecting set	4-9	4-3
CHAPTER 5.	DIRECT SUPPORT MAINTENANCE INSTRUCTIONS		
Section I.	Repair parts and special tools, and equipment	5-1	5-1
II.	Troubleshooting	5-4	5-1
III.	Removal and installation of major components and auxiliaries.	5-6	5-2

*This manual supersedes TM 5-6665-202-15, 8 June 1964 including all changes.

CHAPTER 6.	REPAIR OF MINE DETECTOR SET	6-1	6-1
APPENDIX A.	REFERENCES		A-1
	B. COMPONENTS OF END ITEM LIST		B-1
	C. MAINTENANCE ALLOCATION CHART		C-1

LIST OF ILLUSTRATIONS

<i>Number</i>	<i>Title</i>	<i>Page</i>
1-1	Mine detector set with shipping instructions	1-2
1-2	Schematic wiring diagram	1-4
2-1	Battery, removal and installation	2-1
2-2	Preparations for search operation	2-2
2-3	Controls	2-3
2-4	Starting and stopping the mine detector set	2-5
2-6	Mine detector set circuits	2-6
2-6	Module and Sensitivity Check	2-6
2-7	Detector head cover	2-8
2-8	Detector head, positions and uses	2-8
2-9	Battery adapter, removal and installation	2-9
4-1	Carrying case and inserts, disassembly and reassembly	4-4
4-2	Modules, removal and installation	4-5
5-1	Headset, removal and installation	5-3
5-2	Control box, removal and installation	5-4
5-3	Short handle, detector head and balance coil removal and installation	5-5
5 4	Variometer phasing adjustment	5-7
5-5	Transmitter/Receiver Assembly	5-8
6-1	Battery adapter, disassembly and reassembly	6-3
6-2	Header, removal and installation	6-4
6-3	Terminal board, removal and installation	6-4
6 4	Capacitor, removal and installation	6-5
6-5	Control box, disassembly and reassembly	6-7
6-6	Short handle, detector head and balance coil, disassembly	6-10
FO-1	Electrical schematic diagram	Back of Manual

CHAPTER 1

INTRODUCTION

Section I. GENERAL

1-1. Scope

These instructions are published for the information and guidance of personnel to whom the mine detector is issued. Information is provided on the operation; preventive maintenance services, and organizational and direct support maintenance of the equipment, accessories, component, and attachment.

1-2. Demolition and Administrative Storage

a. For information on the administrative storage of this equipment, refer to TM 740-90-1.

b. For information on the demolition of this equipment, refer to TM 750-244-3.

1-3. Maintenance Forms and Records

Maintenance forms, records and reports which are to be used by maintenance personnel at all maintenance levels are listed in and prescribed by DA PAM 738-750, The Army Maintenance Management System (TAMMS).

Paragraph 1-4 deleted.

Section II. DESCRIPTION AND DATA

1-5. Description

The mine detector is a portable device capable of detecting metallic objects; it is specifically intended for detecting metallic antitank or anti-personnel mines that are buried or hidden from sight. The presence of a metallic object is indicated audibly by a 2,500-cycle tone in the headset. False responses caused by the operation over salt water or magnetic soils are effectively eliminated by a compensating circuit within the mine detector. The design of the mine detector is so compact that it is easily handled, operated, and transported. Figure 1-1 illustrates the mine detector set and provides shipping dimensions.

1-6. Differences Between Models

This manual covers the AN/PSS-11 (Polan Models P153, P158, and P190, Oregon Technical Products Model MD-M, The VP Company Model VP200 and Fourdee Model 4D5000) mine detector sets. The known

differences between the models are the carrying cases and cushion inserts which are not interchangeable. The smaller diameter Receiver and Transmitter Cable, P/N13200E2702 on the Fourdee Model is not interchangeable, but may be used as a replacement cable for all models.

1-7. Identification and Tabulated Data

a. Identification. The AN/PSS-11 Polan Models P153, P158, and P190, the VP Company Model VP200 and Fourdee Model 4D5000) mine detector set has two identification plates.

(1) *Case identification plate.* Located on the front, center of the top case. Specifies nomenclature, manufacturer, and manufacturer's part number.

(2) *Receiver and transmitter assembly identification plate.* Located on the center of the header. Specifies nomenclature, serial number, contract number, manufacturer, and stock number.

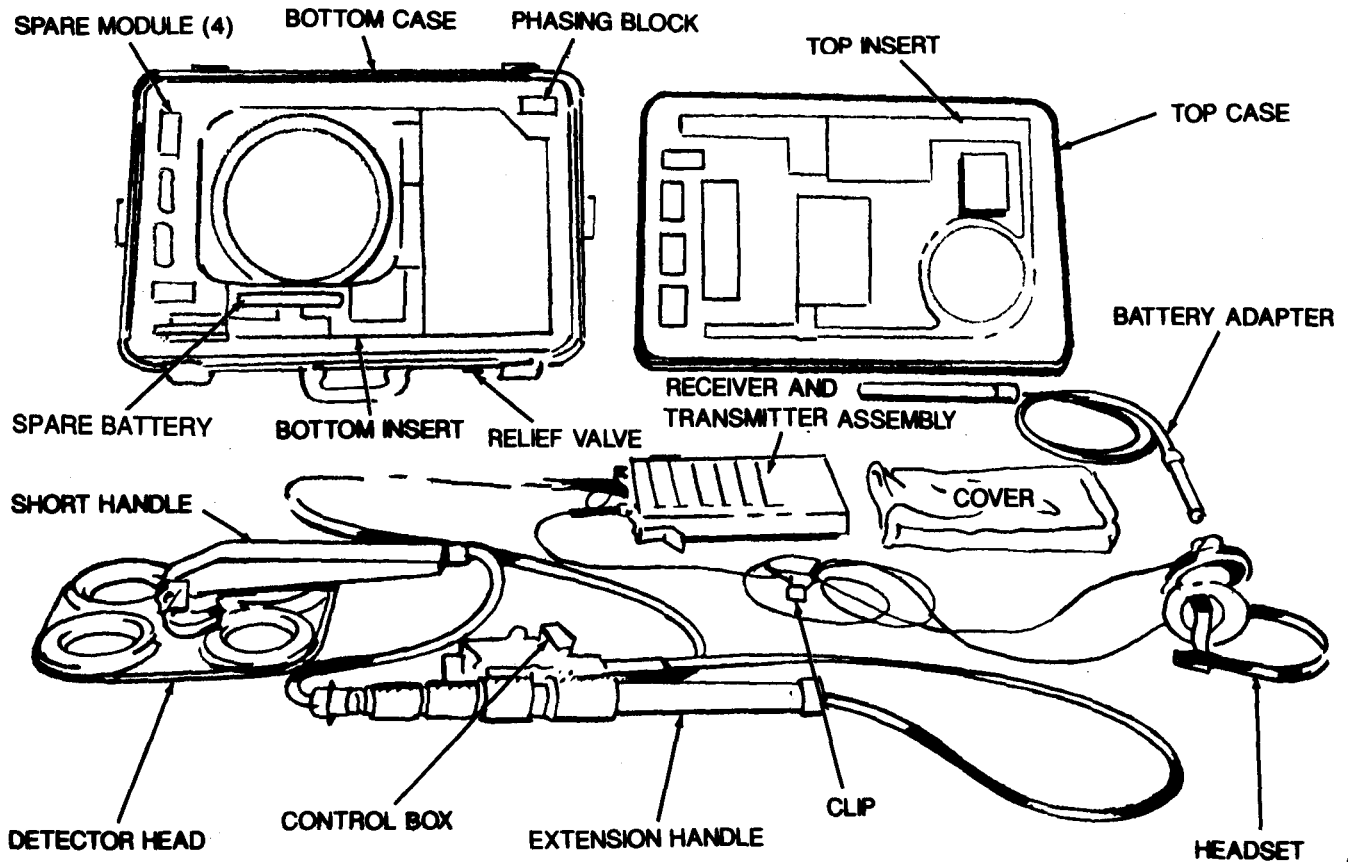

OREGON MODEL MD-M	
SHIPPING	DIMENSIONS
LENGTH	24-3/4 INCHES
WIDTH	16-1/2 INCHES
HEIGHT	7-1/4 INCHES
WEIGHT	32 POUNDS

POLAN MODEL P-153-158-190	
SHIPPING	DIMENSIONS
LENGTH	24-1/4 INCHES
WIDTH	16 INCHES
HEIGHT	7-1/4 INCHES
WEIGHT	30-3/4 POUNDS

FOURDEE MOD	
SHIPPINGS	DIMENSIONS
LENGTH	24-1/2 INCHES
WIDTH	16 INCHES
HEIGHT	7 INCHES
WEIGHT	30 POUNDS

THE VP COMPANY MODEL VP200	
SHIPPING	DIMENSIONS
LENGTH	24 1/4 INCHES
WIDTH	16 INCHES
HEIGHT	7 1/4 INCHES
WEIGHT	36 POUNDS

Figure 1-1. Mine Detector set with shipping dimensions.

b. Tabulated Data.

(1) Receiver transmitter assembly.

Type ----- Transistorized
 Voltage ----- 10 v (Volts)
 Manufacturer ----- Polan Industries or Oregon Technical Products, VP Company and Fourdee, Inc.

(2) Extension handle.

Length:
 Extended ----- 57 in. (inches)
 Collapsed ----- 19 in.

Number of sections ----- 5
 Type joints ----- Friction

(3) Battery.

Quantity ----- 2
 Type ----- Mercury
 Voltage ----- 7.25 to 10.8 v
 Battery life (continuous operation) ----- 3 5 hours

(4) Dimensions and weight.

(a) Polan Models P153, P158, and P190.

Overall length ----- 24 1/4 in.

Overall width ----- 16 in.
 Overall height ----- 7 1/4 in.
 Weight ----- 32 lb (pounds)

(b) Oregon Model MD-M.

Overall length ----- 24 3/4 in.
 Overall width ----- 16 1/2 in.
 Overall height ----- 7 1/4 in.
 Weight ----- 30 3/4 lb.

(c) The VP Company Model VP200.

Overall length ----- 24 1/2 in.
 Overall width ----- 16 in.
 Overall height ----- 7 1/2 in.
 Weight ----- 36 lb

(d) Fourdee Model 4D5000.

Overall length ----- 24 1/2 in.
 Overall width ----- 16 in.

Overall height ----- 7 in.
 Weight ----- 30 lbs.

(5) Detector set characteristics.

Oscillation frequency ----- 2,500 cps (cycles per second)

Temperature range

(operating) ----- -25°F. to +125°F.

Temperature range

(storage) ----- -65°F to +155°F.

Relative humidity

(operating) ----- 100 percent

Relative humidity

(storage) ----- 100 percent

(6) Electrical wiring and schematic diagrams. Refer to figure 1-2 and FO-1 (Located in back of Manual) for the electrical wiring and schematic diagrams.

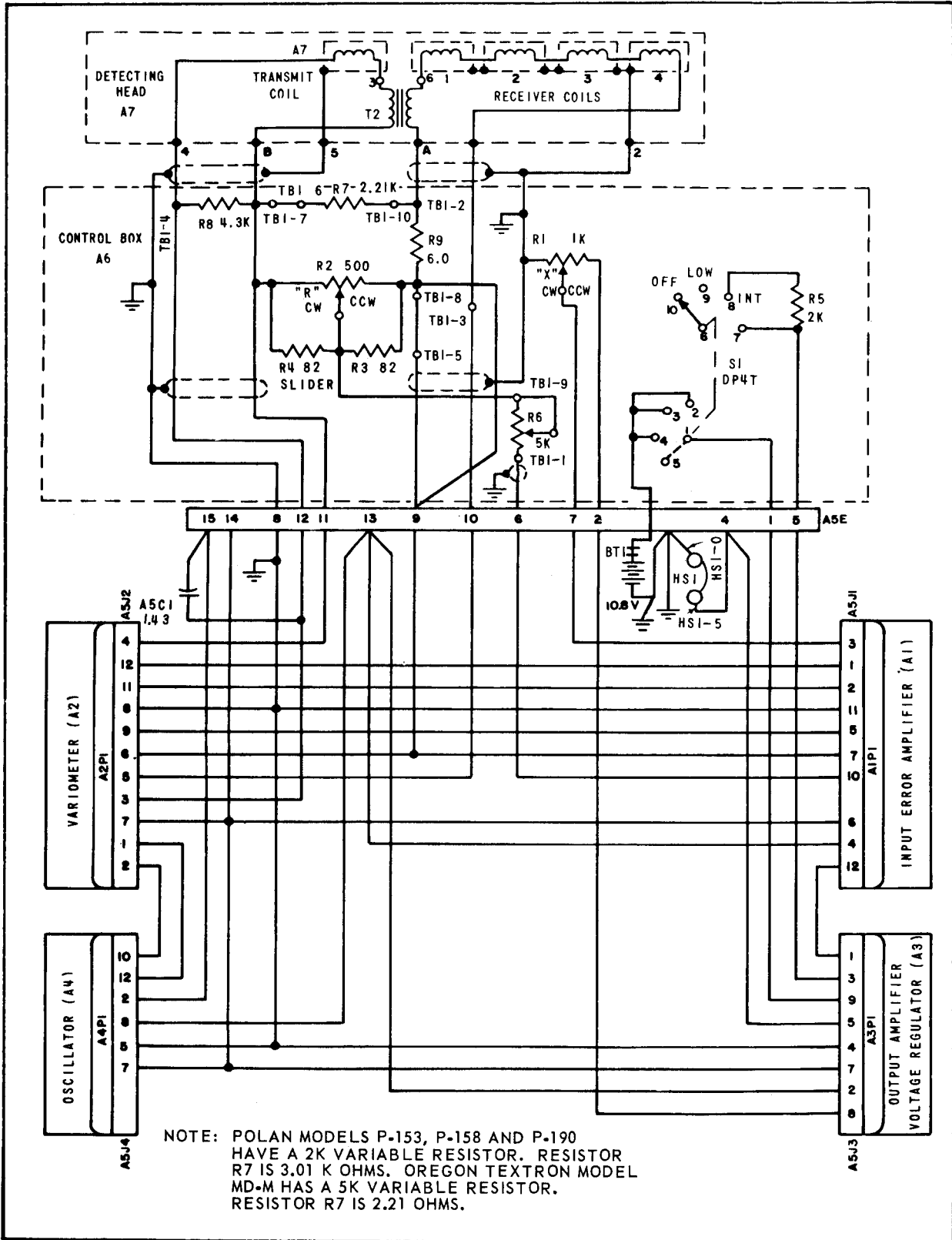

ME 6665-202-13/1-2

Figure 1-2. Schematic wiring diagram.

CHAPTER 2

OPERATING INSTRUCTIONS

Section I. SERVICE UPON RECEIPT OF MATERIEL

2-1. Inspecting and Servicing Equipment

- a. Prepare the mine detector set for operation as outlined in paragraph 2-2.
- b. Perform the daily preventive maintenance services listed in paragraph 3-2.
- c. Carefully inspect the mine detector set for missing parts and possible damage that may have occurred during shipment.
- d. Check the equipment against the packing list. See that the mine detector set is complete as listed.
- e. Inspect the controls for loose or missing mounting hardware and parts.
- f. Inspect the cable assemblies for cuts, frayed insulation, and looseness at connections.
- g. See that the handle assembly slides freely at various lengths when adjusted.
- h. Correct the deficiencies noted or report this condition to field maintenance.

2-2. Installation and Setting-Up Instructions

- a. Remove the detector set from the case

WARNING

Be careful when releasing the spring-type latches that secure the top case of the mine detector set to the bottom case. The latches are under considerable tension and when released, could cause injury to the fingers.

CAUTION

Turn the relief valve (fig. 1-1) two turns counterclockwise before removing. The relief valve equalizes interior and exterior air pressures.

- b. Refer to figure 2-1 and install the battery in the receiver and transmitter assembly
- c. Refer to figure 2-2 and connect the extension handle to the short handle. Adjust the extension handle to the desired length. To connect and adjust extension handle (Model P158), aline slot in male speed with internal pins in female coupling. Push male speed coupling into extreme position against spring and rotate to engage bayonet socket.

- d. Refer to figure 2-2 and adjust the detector head. Refer to figure 2-2 and adjust the headset.

WARNING

Do not operate detector unless yellow with black stripe output amplifier module is installed. Output amplifier modules other than the yellow with black stripe may not alert the operator of low battery voltage. Detectors operated with low battery voltage will not detect metallic objects which endangers the life of the operator.

- e. Refer to figure 2-6 and check module installation.

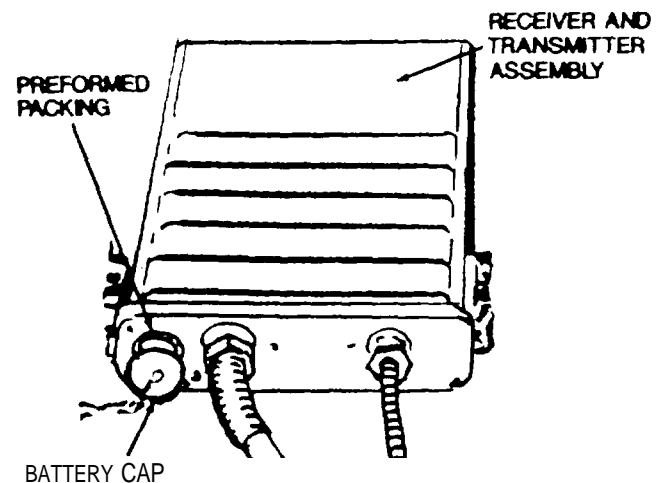

STEP 1. DISCONNECT BATTERY CAP BY TURNING COUNTERCLOCKWISE

STEP 2. INSTALL BATTERY CAP BY TURNING END FIRST. TO REMOVE BATTERY HOLD RECEIVER AND TRANSMITTER ASSEMBLY UPSIDE DOWN AND BATTERY WILL SLIDE OUT

STEP 3 CONNECT BATTERY CAP BY TURNING CLOCKWISE UNTIL SNUG

NOTE: PREFORMED PACKING MUST BE SUFFICIENTLY COMPRESSED TO FORM WATER PROOF SEAL

Figure 2-1. Battery, removal and installation.

CONNECTING AND ADJUSTING EXTENSION HANDLE

- STEP 1. PULL COUPLING BACK AND SLIDE EXTENSION HANDLE ON SHORT HANDLE UNTIL COUPLING ENGAGES LOCK RING ON END OF SHORT HANDLE. ALINE KEYING PIN SO THAT EXTENSION HANDLE FITS FLUSH AGAINST SHORT HANDLE.
- STEP 2. TO EXTEND HANDLE TURN COLLET CLOCKWISE ON HANDLE. TURN AND PULL OUT ON END SECTION OF EXTENSION HANDLE. SECURE SECTION BY TURNING COLLET COUNTERCLOCKWISE UNTIL SNUG. REPEAT THIS PROCEDURE ON REMAINING SECTIONS UNTIL HANDLE IS FULLY EXTENDED OR DESIRED LENGTH IS OBTAINED.

COLLAPSING AND DISCONNECTING EXTENSION HANDLE

- STEP 1. TO COLLAPSE EXTENSION HANDLE LOOSEN COLLETS AND SLIDE SECTIONS FORWARD THEN TIGHTEN COLLETS.
- STEP 2. DISCONNECT EXTENSION HANDLE BY PULLING BACK ON LOCK SLEEVE UNTIL LOCK RING SHORT HANDLE IS RELEASED.

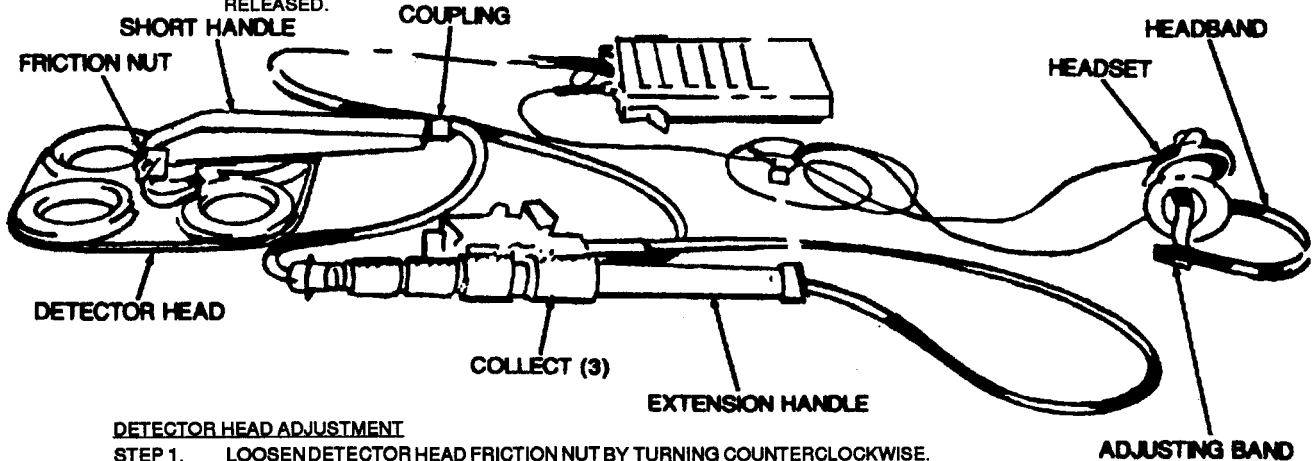

DETECTOR HEAD ADJUSTMENT

- STEP 1. LOOSEN DETECTOR HEAD FRICTION NUT BY TURNING COUNTERCLOCKWISE.
- STEP 2. PLACE DETECTOR HEAD ON TERRAIN AND SHIFT EXTENSION HANDLE TO DESIRED ANGLE OF OPERATION.
- STEP 3. TIGHTEN FRICTION NUT BY TURNING CLOCKWISE UNTIL SNUG.

HEADSET ADJUSTMENT

- STEP 1. PLACE HEADSET ON HEAD.
- STEP 2. SLIDE ADJUSTING BAND IN OR OUT OF HEADBAND UNTIL HEADSET FITS HEAD.

Figure 2-2. Preparations for search operation.

Section II. MOVEMENT TO A NEW WORKSITE

2-3. Dismantling for Movement

a. Preparation for Movement.

(1) Refer to figure 2-1 and remove the battery from the receiver and transmitter assembly. Place the battery in the compartment provided in the bottom case.

(2) Refer to figure 2-2 and collapse and disconnect the extension handle. To collapse and disconnect extension handle on Model P158, rotate male speed coupling until bayonet socket is free at internal pins in female speed coupling, and disconnect.

(3) Place the receiver and transmitter assembly, detector head, and headset in their proper positions in the carrying case.

(4) Place the top case on the bottom case and secure with the six latches provided on the bottom case.

CAUTION

Be careful when closing the carrying case. The top case will fit onto the bottom case in only one way. Damage to the case latches will result from incorrect closure.

CAUTION

Turn the relief valve (fig. 1-1) two turns counterclockwise before latching the top case to the bottom case. After securing the case, close the relief valve by turning it clockwise until snug. This procedure minimizes differences between interior and exterior air pressures.

b. Movement. The mine detector set case is provided with a handle for carrying, and is easily transported. If the movement requires greater than walking distance, the detector set may be loaded on any vehicle as the components are cushioned against shock, and the case is designed of sturdy material for this purpose.

CAUTION

Exercise care when moving the mine detector set either in or out of the case. Be extremely careful not to bump or jar the equipment. If the detector set is to be moved over rough terrain it must be secured in the case unless it is being operated.

NOTE

If the mine detecting set is accidentally dropped or subjected to hard bumps, it should be thoroughly inspected for damage before it is operated.

2-4. Reinstallation After Movement

Refer to paragraph 2-2 for setting-up instructions after movement.

Section III. CONTROLS AND INSTRUMENTS**2-5. General**

This section describes, locates, illustrates, and furnishes the operator, or organizational maintenance personnel sufficient information about the various controls for proper operation of the mine detector set.

2-6. Controls and Instruments

Refer to figure 2-3 for a complete description of the controls.

NOTE: NORMAL POSITIONS OF CONTROLS STATED HERE ASSUME AN AMBIENT TEMPERATURE OF 70 F. NORMAL POSITIONS MAY VARY WITH EXTREMES IN AMBIENT TEMPERATURE.

NOTE: NORMAL POSITIONS OF THE TWO CONTROL KNOBS ARE ALSO OBTAINED WHEN INDEX MARK ON EACH KNOB IS ALLIGNED WITH RELATED INDEX MARK ON CONTROL BOX.

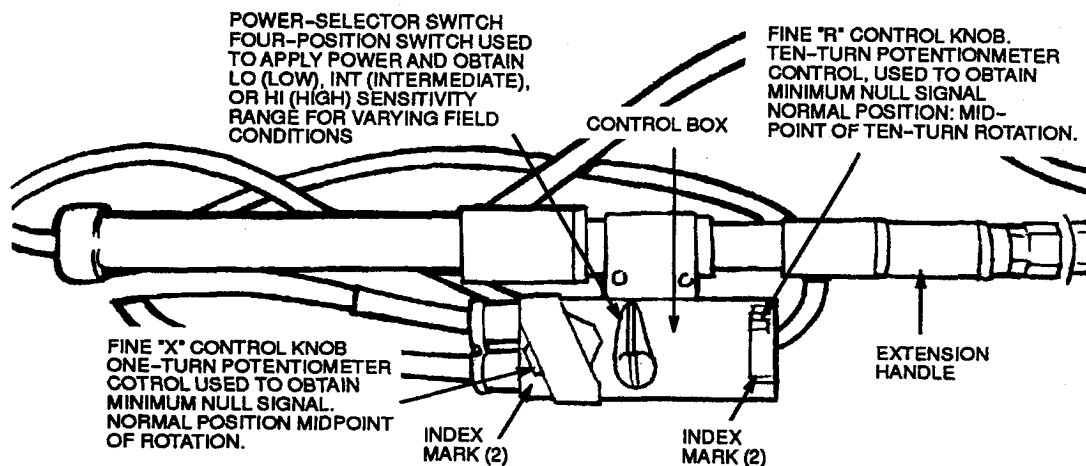

Figure 2-3. Controls.

Section IV. OPERATION UNDER USUAL CONDITIONS**2-7. General**

a. The instructions in this section are published for the information and guidance of the personnel responsible for the operation of the AN/PSS-11 mine detector set.

b. The operator must know how to perform every operation of which the mine detector set is capable. This section gives instructions on starting, operating, and stopping the mine detector set. Operation under unusual environmental conditions is also explained. Since terrain and weather are so variable, the operator may have to adapt stated procedures to meet actual field conditions.

2-8. Starting

a. Preparation for Starting.

- (1) Perform the setting-up instructions (para 2-2).
- (2) Perform the daily preventive maintenance services (para 3-2).
- (3) Position headset on head.
- (4) Attach receiver and transmitter assembly (fig. 1-1) to pistol belt.

b. *Starting.* Refer to figure 2-4 and start the mine detector set.

2-9. Stopping

Refer to figure 2-4 and stop the mine detector set.

CAUTION

Do not leave the battery in the mine detector set when the set is not in use. The battery will sometimes corrode, causing damage to the terminals inside the battery housing. (Refer to fig. 2-1 for removal of battery).

2-10. Mine Detector Set Operation

a. *General.* The mine detector set functions electronically as an audio frequency, mutual inductance bridge. The coils in the detector head, comprising the mutual inductance bridge, are electrically balanced. The transmitter coils send out electromagnetic waves, setting up a magnetic field with a radius of from 3 to 4 feet around the detector. When a metallic object is encountered, the magnetic field set up by the detector head becomes distorted. This distortion results in an unbalance in the mutual inductance bridge resulting in a signal increase in the headset. A phase discriminating circuit built into the mine detector set cancels out false signals caused by salt water or magnetic soil. Only signals caused by metallic objects are transmitted to the headset. Figure 2-5 illustrates the mine detector set circuits in block diagram form.

WARNING

Do not operate the mine detector set if it is improperly adjusted. Cease searching suspected mined areas immediately if faulty signal responses or other indications of improper operation are detected.

WARNING

Do not operate detector unless yellow with black stripe output amplifier module is installed. Output amplifier modules other than the yellow with black stripe may not alert the operator of low battery voltage. Detectors operated with low battery voltage will not detect metallic objects, which endangers the life of the operator.

WARNING

Do not operate the mine detector set prior to performing preliminary adjustment and sensitivity check. Faulty signal responses or other indications of improper operation endangers the life of the operator.

b. *Preliminary Adjustment for Headset Signal.* Refer to figure 2-4 and adjust the controls for a minimum null.

c. *Variometer Phasing and Sensitivity Check.* Refer to figures 2-6 and 2-6.1 and check the mine detector for variometer phasing and sensitivity. If the detector does not meet minimum requirements specified in figures 2-6 and 2-6.1, turn the detector in for repair.

d. *Using the Detector Head.* Refer to figure 2-7 for proper positions and use of the detector head.

WARNING

If more than one mine detector set is being used in the area, keep the detector heads at least 20 feet apart, to avoid signal interference. A loud beat-type signal will be heard when units are operating too close to each other.

WARNING

Cease searching suspected mined area if the usual low level (2,500 cps) signal changes to a sharp piercing high level signal. When battery voltage drops below 7 volts the output amplifier module automatically induces a low raspy signal. Operation of equipment during this condition imperils life as voltage is below the required minimum level for detection of metallic objects.

CAUTION

The detector head cover (fig. 2-8) must be installed on the search head whenever the detector is operated on rough terrain to prevent damage to the search head.

e. *Buried Metallic Object Encountered.* A noted increase in the headset signal volume as the detector head is moved over the ground, is an indication that a metallic object is buried in this particular area. Proceed to locate the exact position of the buried metallic object as outlined in g below.

WARNING

Always keep the detector head parallel to the ground during a search operation. Never allow the detector head to drop or rest on the ground during mine detecting operations in a suspected area.

f. *Searching Areas that Are Covered With Metal Fragments.*

WARNING

Be extremely careful when searching an area that is covered with metal fragments as there is danger of encountering metallic mines yielding signals that might be mistaken for those caused by the metal fragments.

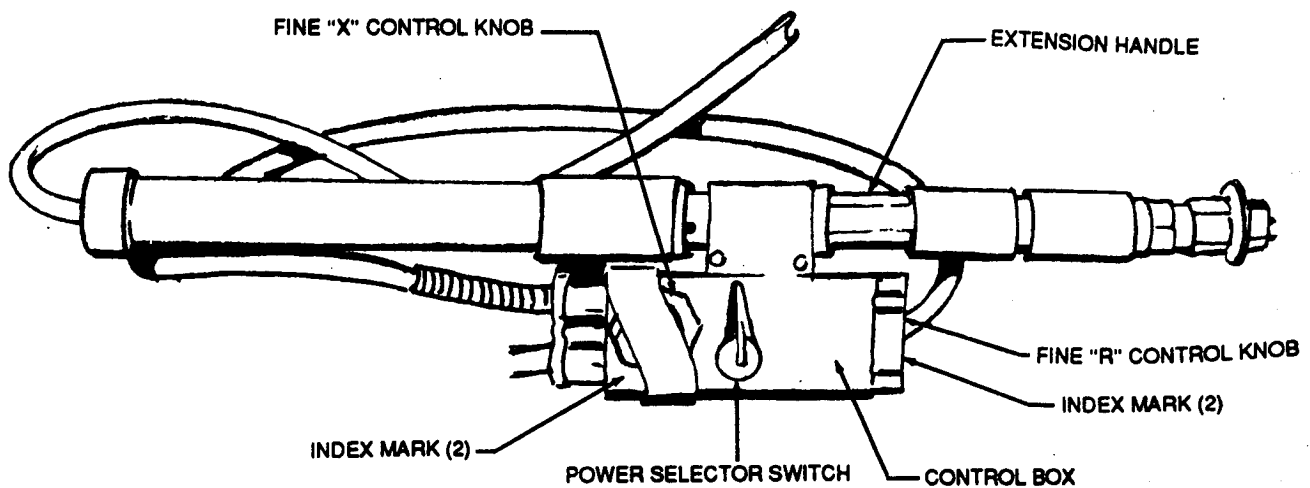
**STARTING:**

STEP 1. HOLD DETECTOR HEAD FIVE FEET ABOVE TERRAIN AND AT LEAST FIVE FEET FROM METALLIC OBJECTS.

STEP 2. TURN POWER SELECTOR SWITCH TO INT POSITION.

STEP 3. ALINE INDEX MARK ON FINE "X" CONTROL KNOB WITH RELATED INDEX MARK ON CONTROL BOX. ALINE FINE "R" CONTROL KNOB IN LIKE MANNER. (2,500 CPS RINGING SIGNAL SHOULD BE HEARD IN HEADSET). ADJUST CONTROL KNOBS UNTIL MINIMUM NULL (SIGNAL) IS OBTAINED.

STEP 4. IF NULL IS NOT OBTAINED. TURN POWER SELECTOR SWITCH TO LO POSITION AND REPEAT STEP 3.

CAUTION: DO NOT START UNIT UNLESS DETECTOR HEAD IS AT LEAST FIVE FEET FROM METALLIC OBJECTS. VOLTAGE INDUCED BY METALLIC OBJECTS CAN SERIOUSLY DAMAGE UNTUNED CIRCUITS.

NOTE: IF MINIMUM NULL CANNOT BE OBTAINED REPORT THE CONDITION TO ORGANIZATIONAL MAINTENANCE.

STOPPING:

TURN POWER SELECTOR SWITCH TO OFF POSITION.

Figure 2-4. Starting and stopping the mine detector set.

When searching over an area that is covered with shrapnel or where metal fragmentation is evident, resultant signals will be similar to those produced where an actual mine is encountered. In searching an area such as this, sweep the ground with the detector head at heights ranging from 3 to 8 inches, depending on the quantity, size, and distribution of metal fragments. Response from small metallic objects will be eliminated, but larger objects such as metallic mines will yield adequate signals.

g. Locating Exact Position of Buried Metallic Object. When a sharp change in signal volume is heard, move the detector head slowly from side to side. Increased signal will be noted as either side of the detector head is

passed over the metallic object; a decrease will be noted as the center of the detector head moves over the buried object. If no decrease in signal volume is noted, as the center of the detector head moves over the buried object, a saturated condition exists. If this occurs, raise the detector head 1 or 2 inches higher and repeat the sweeping motion. If necessary, raise the detector head until a definite change in volume is evident when the detector head moves over the buried object. At this point the detector head is directly over the location of the buried object.

h. Procedure Upon Completion of Search. Turn off the mine detector set when a search operation is completed (para 2-8).

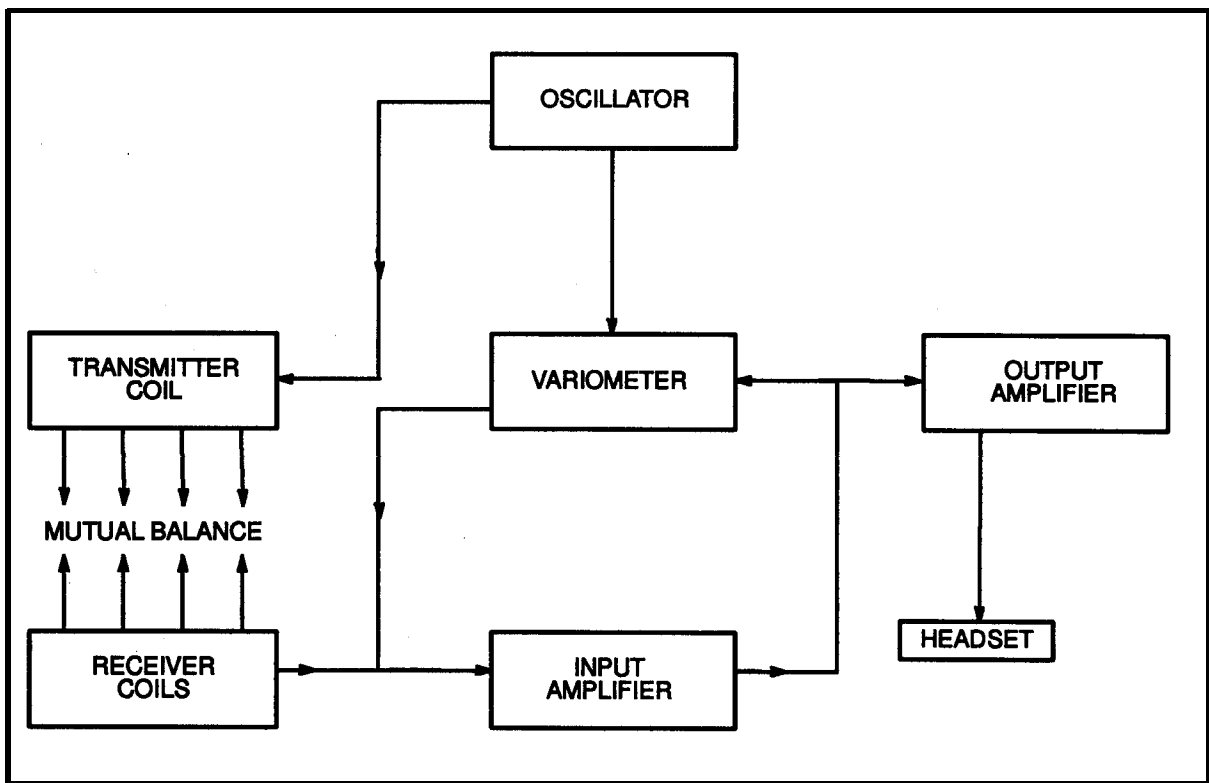

Figure 2-5. Mine detector set circuits

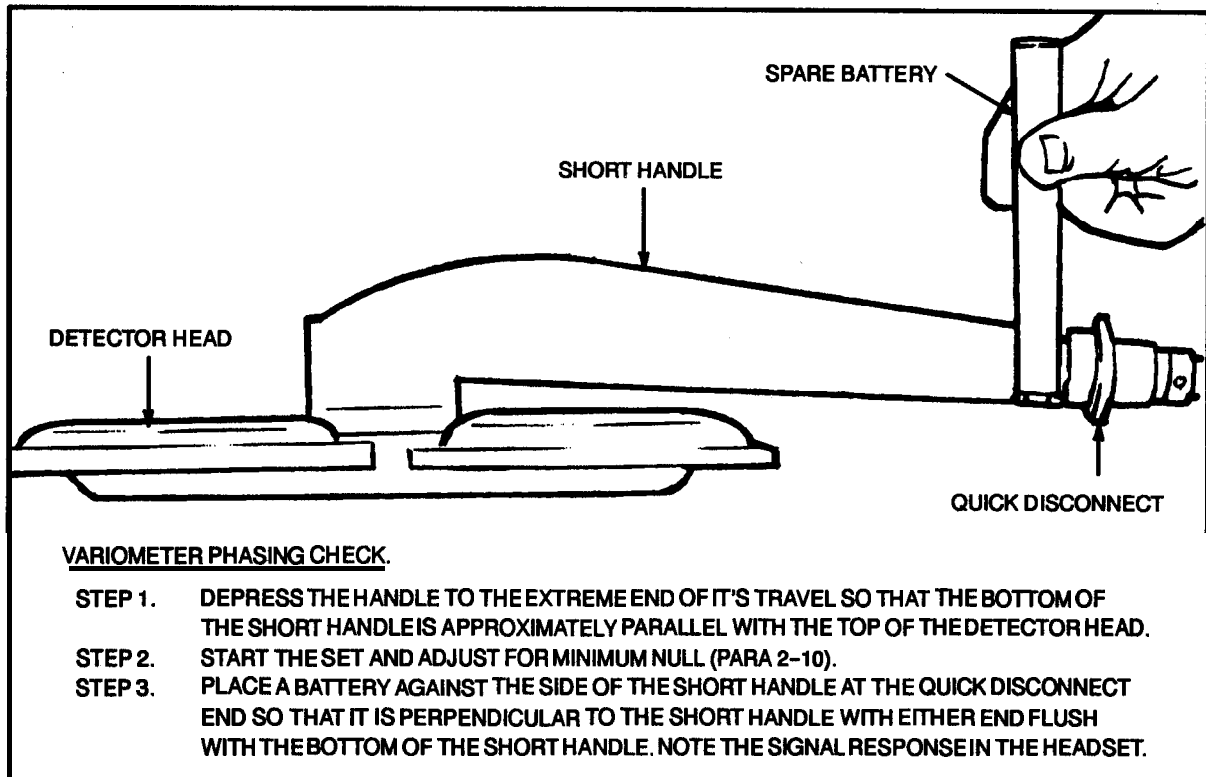
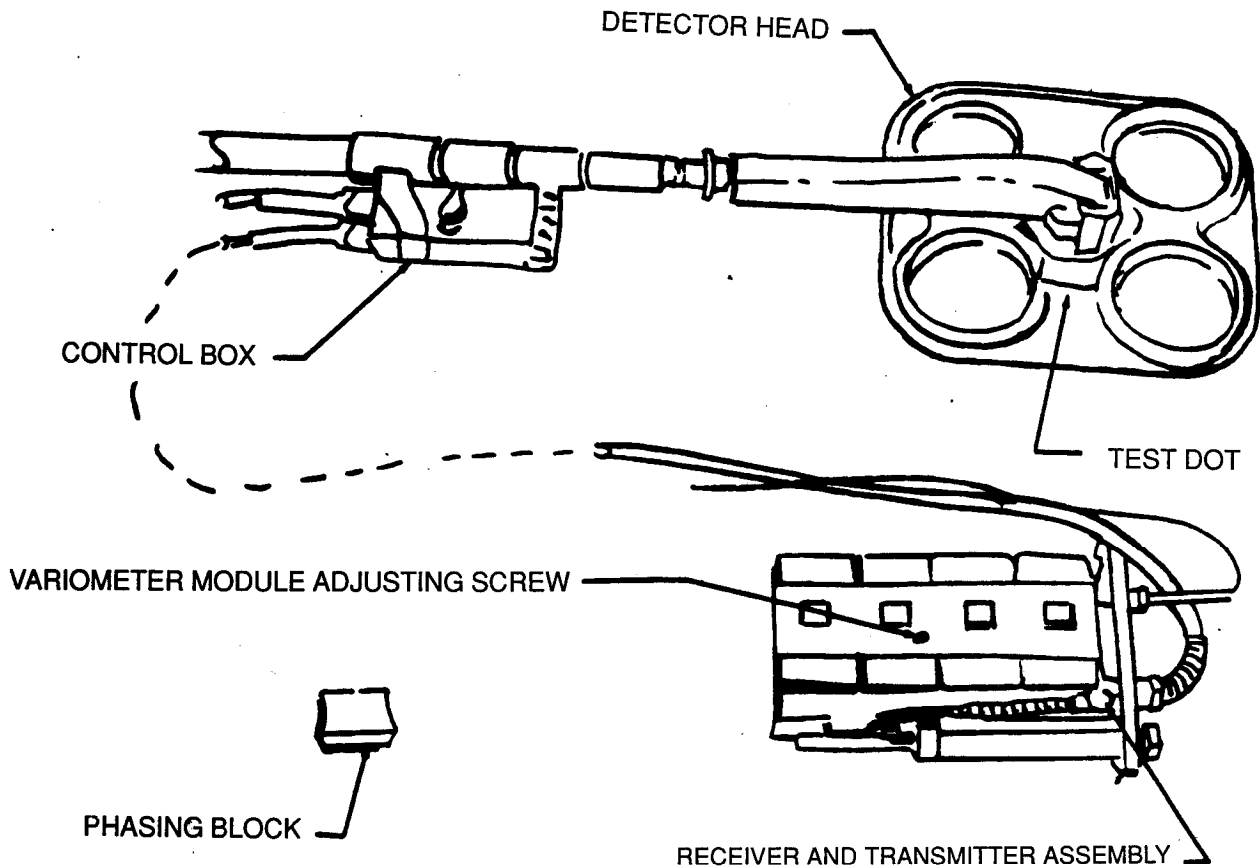

Figure 2-6. Variometer phasing and sensitivity checks
(Sheet 1 of 2).



- STEP 4.** PLACE THE PHASING BLOCK; FIRST OVER THE WHITE TEST DOT ON THE DETECTOR HEAD, AND THEN ON THE SIDE OPPOSITE THE WHITE DOT. NOTE THE SIGNAL RISE IN THE HEADSET.
- STEP 5.** THE SIGNAL RESPONSE WHEN THE PHASING BLOCK IS PLACED ON EITHER SIDE OF THE DETECTOR HEAD, SHOULD BE LESS THAN THE SIGNAL FROM THE BATTERY. A NOTICEABLY HIGHER SIGNAL FROM THE PHASING BLOCK INDICATES INCORRECT VARIOMETER PHASING IN WHICH CASE REPORT THE CONDITION TO ORGANIZATIONAL MAINTENANCE. VARIOMETER PHASING ADJUSTMENT IS PERFORMED AT DIRECT SUPPORT MAINTENANCE.

VARIOMETER PHASING CHECK (ALTERNATE)

- STEP 1.** IN THE CENTER OF A SMOOTHED 3-4 FT. DIAMETER CIRCLE, FREE OF ANY METALLIC OBJECTS, PLACE AN M-16 CARTRIDGE (BULLET END DOWN, PRIMER END LEVEL WITH THE SOIL SURFACE).
- STEP 2.** PLACE THE SEARCH HEAD AT A HEIGHT OF APPROXIMATELY 2 INCHES ABOVE THE SOIL AND AT LEAST 2 FT. FROM ANY METALLIC OBJECT (CARTRIDGE). NULL THE DETECTOR IN THE "INT" POSITION.
- STEP 3.** HOLD THE DETECTOR OFF THE GROUND BETWEEN 5-6 INCHES. PASS THE FRONT TWO COILS SLOWLY OVER THE M-16 CARTRIDGE. TWO DISTINCT PEAKS OF SOUND WITH A VERY NOTICEABLE DECREASE IN SOUND BETWEEN THEM SHOULD BE HEARD IN THE HEADSET. THE TWO PEAKS SHOULD BE APPROXIMATELY EQUAL IN LOUDNESS.

THE 5-6 INCH HEIGHT IS CONSIDERED ACCEPTABLE. IF THE DETECTOR HEAD HEIGHT NEEDS TO BE ADJUSTED TO 4-5 INCHES TO ACHIEVE THE TWO PEAKS, IT IS CONSIDERED MARGINAL. IF THE HEAD HEIGHT NEEDS TO BE ADJUSTED BELOW 4 INCHES TO ACHIEVE THE TWO PEAKS, THE DETECTOR SHOULD BE RETURNED FOR REPAIR.

*Figure 2-6. Variometer Phasing and Sensitivity Checks
(sheet 2 of 2).*

Module Check

WARNING

Do not operate detector unless yellow with black stripe output amplifier module is installed. Output amplifier modules other than the yellow with black stripe may not alert the operator of low battery voltage. Detectors operated with low battery voltage will not detect metallic objects, which endangers the life of the operator.

Check that modules are installed per the colors shown in figure 2-6. (The output amplifier module should be yellow with a black stripe). If any module is missing, or the colors are out of sequence turn the detector in through normal maintenance channels for repair. Users are not to change modules as it can affect the set's calibration. Repairs should be done by authorized personnel only.

WARNING

Do not operate the mine detector set prior to performing sensitivity check. Faulty signal responses or other indications of improper operation endangers the life of the operator.

SENSITIVITY CHECK

- STEP 1. TEST THE SENSITIVITY OF THE SET BY SWITCHING THE POWER SELECTION SWITCH TO HI POSITION AND HOLDING A COIN (OR OTHER SMALL METAL OBJECT) ABOUT 2 INCHES ABOVE THE WHITE DOT ON THE DETECTOR HEAD. A DEFINITE INCREASE IN SIGNAL STRENGTH SHOULD BE HEARD IN THE HEADSET.
- STEP 2. IF THE SIGNAL RESPONSE IS WEAK, REPLACE THE BATTERY IN THE SET (PARA 4-11A) AND REPEAT STEP 1. IF THE SIGNAL RESPONSE IS STILL WEAK, REPLACE THE MODULES (PARA 4-11B). IF THE SIGNAL REMAINS LOW, REPORT THE CONDITION TO ORGANIZATIONAL MAINTENANCE.
- NOTE: DO NOT ALLOW RINGS, WATCHES, OR OTHER METALLIC OBJECTS NEAR THE DETECTOR HEAD WHILE CHECKING THE SET. METALLIC OBJECTS WILL GENERATE A SIGNAL IN THE HEADSET.

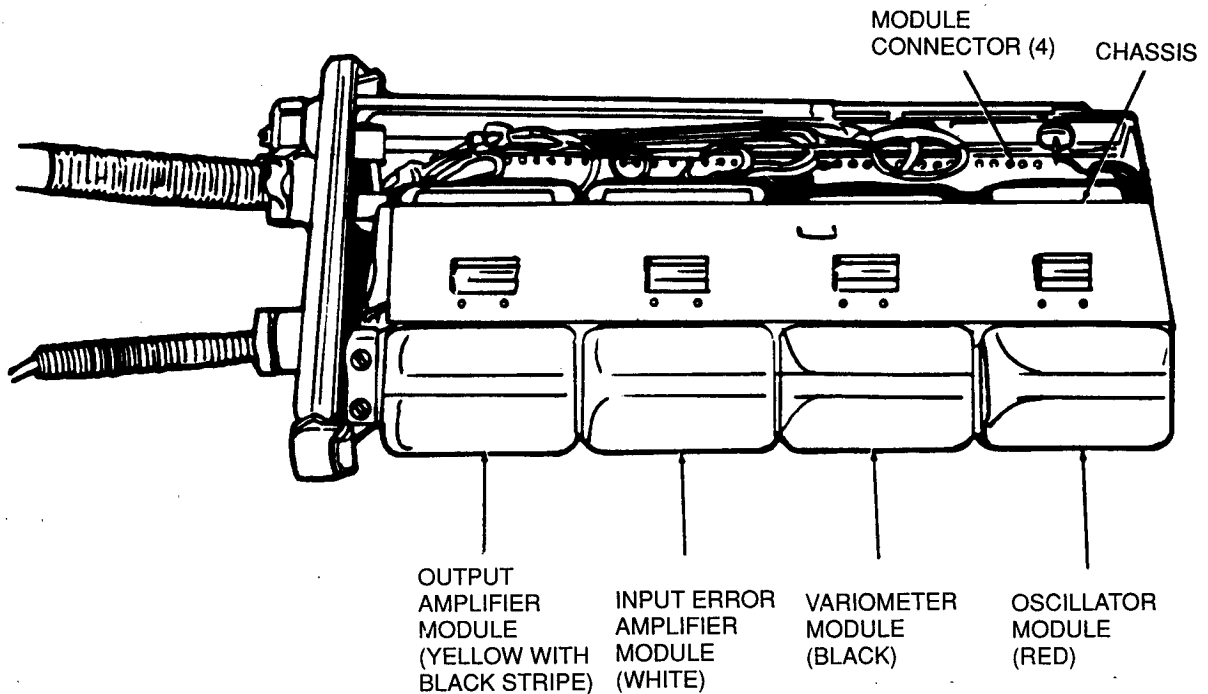
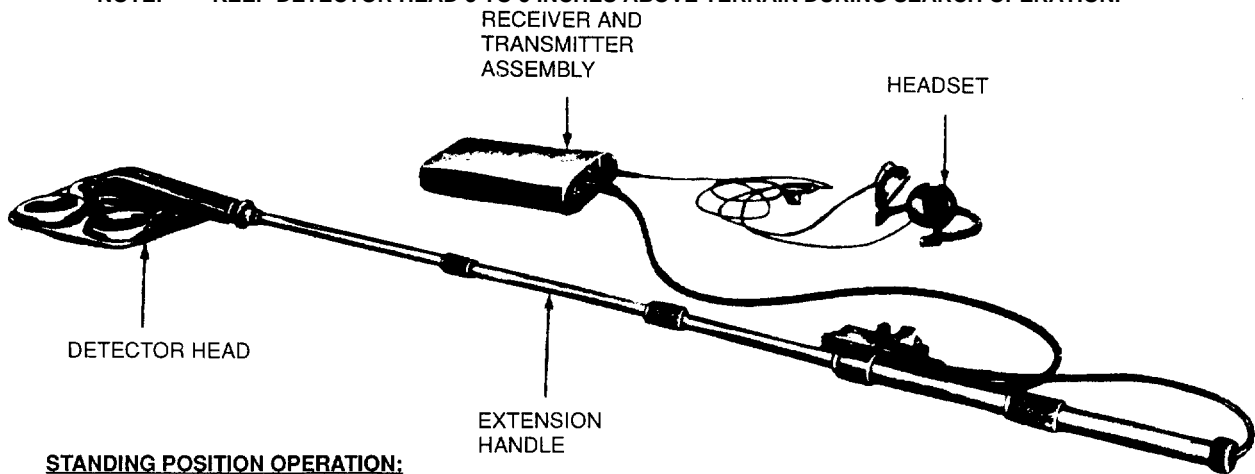

Figure 2-6.1. Module and Sensitivity Checks.

WARNING: NEVER ALLOW DETECTOR HEAD TO TOUCH OR REST ON TERRAIN DURING SEARCH OPERATION OF SUSPECTED MINED AREA.

NOTE: KEEP DETECTOR HEAD 3 TO 5 INCHES ABOVE TERRAIN DURING SEARCH OPERATION.



STANDING POSITION OPERATION:

- STEP 1. GRASP EXTENSION HANDLE IN HANDS.
- STEP 2. MAKE WIDE SWEEPING MOTIONS FROM LEFT TO RIGHT WHILE WALKING FORWARD SLOWLY.

PRONE POSITION OPERATION:

- STEP 1. COLLAPSE EXTENSION HANDLE TO DESIRED LENGTH AND ADJUST DETECTOR HEAD FOR PROPER ANGLE OF OPERATION (PARA 2-2).
- STEP 2. ASSUME PRONE POSITION, SUPPORTING WEIGHT ON LEFT FOREARM.
- STEP 3. HOLDING EXTENSION HANDLE IN RIGHT HAND, USE RIGHT FOREARM AS LEVERAGE ON REAR OF EXTENSION HANDLE TO KEEP DETECTOR HEAD PARALLEL WITH TERRAIN.
- STEP 4. MAKE WIDE SWEEPING MOTIONS FROM LEFT TO RIGHT WHILE CRAWLING FORWARD SLOWLY.

Figure 2-7. Detector head, positions and uses.

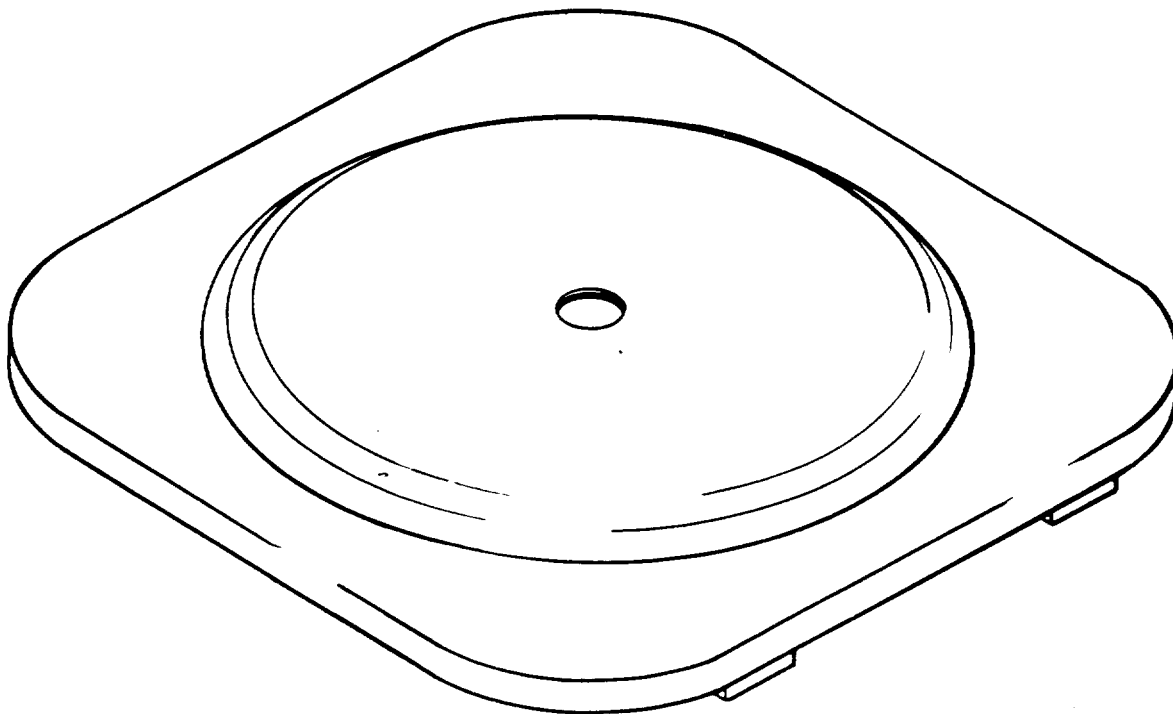

Figure 2-8. Detector head cover.

Section V. Operation Under Unusual Conditions

2-11. Operation in Temperatures Below 40° F.

The temperature of the battery must be kept at 40° F. or above. To accomplish this, the operator can wear the transmitter-receiver assembly under his outer clothing, or use the battery adapter. Refer to figure 2-9 for instructions on installing and removing the battery adapter. After the battery adapter is installed in the receiver and transmitter assembly, place the battery tube inside the clothing so that body heat of the operator will keep the battery warm and allow the mine detector set to function properly. Allow a 2-minute warmup time before operating set. When the mine detector set is taken inside a heated building after it has been exposed to extreme cold, moisture will form on the metallic surfaces. Wipe all moisture from the equipment before securing in the case.

2-12. Operation in Dusty or Sandy Areas

When operating the mine detector set in dusty or sandy area, special precautions should be taken to keep dust and dirt out of the equipment. Make sure the latches that secure the case on the transmitter are locked.

2-13. Operation Under Rainy or Humid Conditions

When operating the mine detector set under rainy or humid conditions, keep the set wiped dry as much as possible. Make sure the two latches on the sides of the transmitter are secured. Make sure all components are tightly sealed. Check all cables for loose connections. After operation in rainy or humid conditions, store the detector set in a warm, dry area to allow the moisture to evaporate.

2-14. Operation in Salt Water Areas

Salt water air and spray are highly corrosive to many parts of the metallic mine detector set. Wipe the set dry as often as possible to avoid corrosion. After operation is completed, rinse any salt water off the detector with fresh water, and dry thoroughly. Make sure all components are tightly sealed and cable assembly bushings are tight.

NOTE: INSTALL BATTERY ADAPTER COMPONENTS BY TURNING THEM CLOCKWISE. REMOVE COMPONENTS BY TURNING THEM COUNTERCLOCKWISE.

NOTE: TIGHTEN BATTERY CASE ADAPTER AND TUBE ADAPTER UNTIL SNUG. PREFORMED PACKING MUST BE SUFFICIENTLY COMPRESSED TO FORM WATERPROOF SEAL.

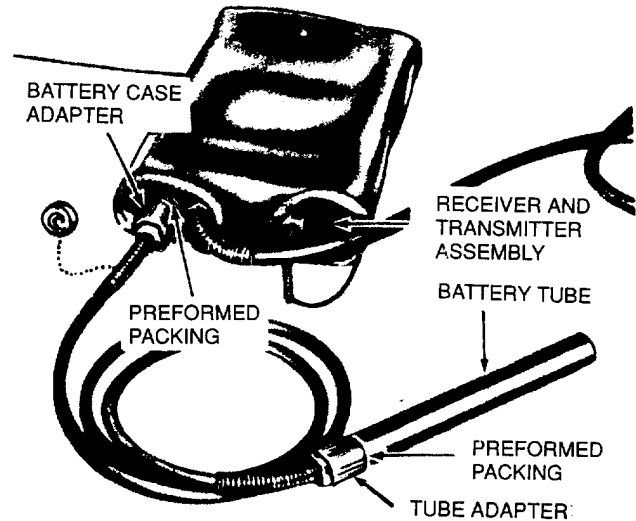

BATTERY ADAPTER INSTALLATION:

- STEP 1. REMOVE BATTERY FROM RECEIVER AND TRANSMITTER ASSEMBLY (PARA 4-11A).
- STEP 2. INSTALL BATTERY CASE ADAPTER IN RECEIVER AND TRANSMITTER ASSEMBLY.
- STEP 3. REMOVE BATTERY TUBE FROM TUBE ADAPTER, INSTALL BATTERY IN BATTERY TUBE, INSERTING POSITIVE (PLUS) END FIRST. INSTALL BATTERY TUBE ON TUBE ADAPTER.

BATTERY ADAPTER REMOVAL:

- STEP 1. REMOVE BATTERY CASE ADAPTER FROM RECEIVER AND TRANSMITTER ASSEMBLY.
- STEP 2. REMOVE BATTERY TUBE FROM TUBE ADAPTER, TILT BATTERY TUBE ON TUBE ADAPTER.
- STEP 3. INSTALL BATTERY IN RECEIVER AND TRANSMITTER ASSEMBLY (PARA 4-11a).

NOTE: STORE ASSEMBLED BATTERY ADAPTER IN TOP OF CARRYING CASE.

Figure 2-9. Battery adapter, removal and installation.

CHAPTER 3

OPERATOR/CREW MAINTENANCE INSTRUCTIONS

Section I. LUBRICATION INSTRUCTIONS

No lubrication of the mine detector set will be performed by the operator/crew personnel.

Section II. PREVENTIVE MAINTENANCE CHECKS AND SERVICES

3-1. General

To insure that the mine detecting set is ready for operation at all times, it must be inspected systematically so that defects may be discovered and corrected before they result in serious damage or failure. The necessary preventive maintenance checks and services to be performed are listed as described in table 3-1. The item numbers indicate the sequence of minimum inspection requirements. Defects discovered during operation of the unit will be noted for future correction to be made as soon as operation has ceased. Stop operation immediately if a deficiency

is noted during operation which would damage the equipment if operation were continued. All deficiencies and shortcomings will be recorded together with the corrective action taken on form 2404 at the earliest possible opportunity.

3-2. Preventive Maintenance Checks and Services

Refer to table 3-1 and perform the daily preventive maintenance checks and services. If equipment is not in use, perform maintenance checks and services on a weekly basis.

Table 3-1. Preventive Maintenance Checks and Services
Operator Maintenance Category Daily Schedule (or weekly)

Interval		sequence No.		Item to be inspected	Procedure	Paragraph reference
Before operation	During operation	After operation				
1				Receiver and Transmitter	Clean receiver and transmitter. Check for corrosion, missing hardware or other defects.	para 3-8
2	10			Battery	Check for proper operation Check for corrosion or other damage.	para 2-2 para 3-9
		13			Remove battery from battery tube	para 2-2
3		14		Headset	Clean headset	para 3-10
4	11			Cables	Check for audio tone	para 3-4
5		15		Battery Adapter	Check for worn, cracked or frayed cables.	para 2-2
6		16		Battery Adapter	Check for damaged or defective battery adapter and worn, cracked or frayed cable.	para 3-7
7				Detector Head and Balance Coil Assembly	Clean assembly and check for damage and defects	para 3-11
				Case	Clean case and check for worn, damaged, or defective case, lining, seal, latches, handle, or vent.	paras 2-2 and 3-6

Table 3-1. Preventive Maintenance Checks and Services - Continued
Operator Maintenance Category Daily Schedule (or weekly)

Interval and sequence No.			Item to be inspected	Procedure	Paragraph reference
Before operation	During operation	After operation			
8			Bag (Receiver and Transmitter)	Check for worn, damaged or defective bag.	
9	12		Controls	Inspect for damage and loose mounting. With set operating, check for proper operation	para 2-2 paras 2-2 and 3-4

Section III. TROUBLESHOOTING

3-3. General

a. This section contains troubleshooting information for locating and correcting most of the operating trouble which may develop in the mine detecting set. Each malfunction for an individual component, unit, or system is followed by a list of tests or inspections which will help you to determine probable causes and corrective actions to take. You should perform the tests/inspections and corrective action in the order listed.

b. This manual cannot list all malfunctions that may occur, nor all tests or inspections and corrective actions. If a malfunction is not listed or is not corrected by listed corrective actions, notify organizational maintenance personnel.

3-4. Troubleshooting

Refer to chart 3-1 and troubleshoot a malfunctioning mine detector set.

Chart 3-1. Troubleshooting

MALFUNCTION	TEST OR INSPECTION	CORRECTIVE ACTION
MINE DETECTOR SET		
1. NO INCREASED HEADSET TONE WHEN METAL OBJECT IS POSITIONED NEAR THE DETECTOR HEAD.		Mine detector set improperly adjusted. Adjust controls properly (para 2-10).
2. NO OUTPUT FROM DETECTOR HEAD.		Mine detector set improperly adjusted. Adjust controls properly (para 2-10).

Section IV. MAINTENANCE OF THE MINE DETECTING SET

3-5. General

In addition to services described in paragraph 3-2, the operator will perform the following maintenance of the mine detecting set.

3-6. Mine Detector Set Case (fig. 1-1)

a. *Inspection.* Inspect for loose mountings, missing parts and damaged or defective case, handle, latches, vent, lining or seals:

b. *Cleaning.* Wipe all surfaces of the case with a clean cloth dampened slightly with cleaning solvent (Fed. Spec. P-D-680).

3-7. Battery Adapter Inspection

Inspect battery adapter (fig. 1-1) for breaks, cracks, corrosion, damaged threaded areas or other defects. Refer all defects to organizational maintenance personnel.

3-8. Receiver and Transmitter Assembly (fig. 1-1)

a. *Inspection.* Inspect for breaks, cracks, rust, loose or missing hardware or other damage. Refer all defects to organizational maintenance personnel.

b. *Cleaning.* Wipe the receiver and transmitter with a clean, dry cloth.

3-9. Battery Inspection

Inspect the battery for corrosion or other damage. Make sure that the paper jacket around the battery is not damaged. Refer all defects to organizational maintenance personnel.

3-10. Headset Assembly (fig. 1-1)

a. *Inspection.* Inspect for defective earphones (no audio tone, para 2-2) and damaged, faulty, loose, or missing parts.

b. Service. Wipe the headset with a clean cloth and tighten any loose connections. Refer all defects to organizational maintenance personnel.

3-11. Detector Head and Balance Coil Assembly

a. Inspection.

(1) Inspect the detector head (fig. 1-1) for breaks, cracks, damaged threaded areas, corroded electrical leads, or other defects.

(2) Refer all defects to organizational maintenance personnel.

b. Service. Wipe any accumulation of dirt or moisture from the detector head and balance coil assembly with a clean, dry cloth.

CAUTION

Do not use cleaning solvent on plastic parts of mine detector set. The components may be damaged if they are cleaned with some types of solvent.

CHAPTER 4

ORGANIZATIONAL MAINTENANCE INSTRUCTIONS

Section I. SERVICE UPON RECEIPT OF MATERIEL

4-1. Inspecting and Servicing the Equipment

a. Battery Adapter.

(1) *Inspection.* Inspect battery adapter (fig. 2-9) for breaks, cracks, corrosion, damaged threaded areas, or other defects. Replace a damaged or defective battery adapter.

(2) *Servicing.* Wipe the battery adapter with a clean, dry cloth.

b. Battery.

(1) *Inspect.* Refer to paragraph 3-9 and inspect the battery.

(2) *Servicing.* Wipe the battery with a clean, dry cloth.

NOTE

Discard cloth after wiping battery clean. Traces of battery corrosion absorbed by the cloth may damage other parts of the set.

(3) *Test.* Refer to paragraph 4-11 and test battery. Replace a weak, damaged, or defective battery.

4-2. Installation

Refer to paragraph 2-2 for installation of the mine detecting set.

Section II. MOVEMENT TO A NEW WORKSITE

Refer to paragraphs 2-3 and 2-4 for instructions on moving the mine detecting set to a new worksite.

Section III. REPAIR PARTS, SPECIAL TOOLS, AND EQUIPMENT

4-3. Special Tools and Equipment

No special tools are required to perform organizational maintenance on the mine detecting set.

4-4. Maintenance Repair Parts

Repair parts are listed and illustrated in the repair parts and special tools list covering organizational maintenance for this equipment in TM 5-6665-202-23P. ■

Section IV. LUBRICATION INSTRUCTIONS

No lubrication of the mine detecting set will be performed by organizational maintenance personnel.

Section V. PREVENTIVE MAINTENANCE CHECKS AND SERVICES

4-5. General

To insure that the mine detecting set is ready for operation at all times, it must be inspected systematically so that defects may be discovered and corrected before they result in serious damage or failure. The necessary preventive maintenance checks and services to be performed are listed as described in table 4-1. The item numbers indicate the sequence of minimum inspec-

tion requirements. Defects discovered during operation of the unit will be noted for future correction to be made as soon as operation has ceased. Stop operation immediately if a deficiency is noted during operation which would damage the equipment if operation were continued. All deficiencies and shortcomings will be recorded together with the corrective action taken on form 2404 at the earliest possible opportunity.

**Table 4-1. Preventive Maintenance Checks and Services
Organizational Maintenance Category Monthly Schedule (or quarterly)**

Sequence number	Item to be Inspected	Procedures	Paragraph References
2	Battery	Clean corroded battery. Test battery voltage. Replace a weak, damaged, or defective battery.	para 4-11a
	Headset	Check headset for damage, defects, and proper tone response.	para 4-8
3	Battery adapter	Replace damaged or defective battery adapter and cable. Test battery adapter for continuity.	para 4-10
4	Detector head and balance coil assembly	Tighten loose mounting.	
5	Case	Tighten loose mounting. Replace worn, damaged or defective case, lining seal, handle latches, or vent.	para 4-9
6	Modules	Replace damaged or defective modules.	para 4-11b

4-6. Preventive Maintenance Checks and Services

Refer to table 4-1 and perform the monthly preventive

maintenance checks and services. If equipment is not in use, perform maintenance checks and services on a quarterly basis.

Section VI. TROUBLESHOOTING

4-7. General

a. This section contains troubleshooting information for locating and correcting most of the operating trouble which may develop in the mine detecting set. Each malfunction for an individual component, unit, or system is followed by a list of tests or inspections which will help you to determine probable causes and corrective actions to take. You should perform the tests/inspections and corrective action in order listed.

b. This manual cannot list all malfunctions that may occur, nor all tests or inspections and corrective actions. If a malfunction is not listed or is not corrected by listed corrective actions, notify direct support maintenance personnel.

4-8. Troubleshooting

Refer to chart 4-1 and troubleshoot a malfunctioning mine detector set.

Chart 4-1. Troubleshooting

MALFUNCTION	TEST OR INSPECTION	CORRECTIVE ACTION
MINE DETECTOR SET		
1. MINE DETECTOR SET INOPERATIVE WITH POWER ON.		
	Step 1. Test battery. If battery voltage is below 8.5 volts, replace battery.	
	Step 2. Replace modules. Refer suspect module(s) to direct support maintenance personnel for testing, repair, or replacement.	

Chart 4-1. Troubleshooting - Continued

MALFUNCTION	TEST OR INSPECTION	CORRECTIVE ACTION
MINE DETECTOR SET-Continued		
2. NO INCREASED HEADSET TONE WHEN METAL OBJECT IS POSITIONED NEAR THE DETECTOR HEAD.		
	Step 1. Test battery. If battery voltage is below 8.5 volts, replace battery.	
	Step 2. Replace modules. Refer suspect module(s) to direct support maintenance personnel for testing, repair, or replacement.	
3. NO OUTPUT FROM DETECTOR HEAD.		
	Step 1. Test battery. If battery voltage is below 8.5 volts, replace battery.	
	Step 2. Replace oscillator module. Refer suspect module to direct support maintenance personnel for testing, repair, or replacement.	
HEADSET		
1. HEADSET SIGNAL ABSENT OR INTERMITTENT WHEN DETECTOR SET IS TURNED ON.		
	Step 1. Test battery. If battery voltage is below 8.5 volts, replace battery.	
	Step 2. Check to see if battery cap is tight and clean.	

Chart 4-1. Troubleshooting - Continued

MALFUNCTION	TEST OR INSPECTION	CORRECTIVE ACTION
HEADSET-CONTINUED		
		Clean inside of battery cap and remove any corrosion. Tighten cap securely.
Step 3.	Replace output amplifier module.	Refer suspect module to direct support maintenance personnel for testing, repair or replacement.
Step 4.	Replace headset.	Refer suspect headset to direct support maintenance personnel for testing, repair, or replacement.

Chart 4-1. Troubleshooting - Continued

MALFUNCTION	TEST OR INSPECTION	CORRECTIVE ACTION
HEADSET-CONTINUED		
2. RASPY (LOW VOLUME OR AMPLITUDE) SIGNAL HEARD IN HEADSET.		
	Step 1. Test battery.	If battery voltage is below 8.5 volts, replace battery.
	Step 2. Replace amplifier module.	Refer suspect module to direct support maintenance personnel for testing, repair, or replacement.

Section VII. MAINTENANCE OF MINE DETECTING SET

4-9. Carrying Case

a. Disassembly. Disassemble the carrying case and inserts according to sequence of index numbers assigned to figure 4-1.

b. Cleaning, Inspection, and Repair.

(1) Wipe the inserts with a clean, dry cloth.

(2) Clean the case with an approved cleaning solvent and dry thoroughly.

(3) Remove any glue deposits from the carrying case after inserts are removed, and before replacing inserts.

(4) Clean the latches, handles, and pressure relief valves with a clean cloth dampened slightly with an approved cleaning solvent.

(5) Inspect the cushion inserts for cuts, tears, embedded foreign objects, deformed compartments, or other defects.

(6) Inspect the ease for breaks, cracks, dents, holes, corrosion, or other defects.

(7) Inspect the handles for proper operation, breaks, bends, loose mounting hardware, or other defects.

(8) Inspect the latches for bends, rust, loose mounting hardware, or other defects.

(9) Inspect the pressure relief valves for proper operation, damaged threaded areas, obstructed air ports, corrosion, or other defects.

(10) Replace a damaged component as necessary.

c. Reassembly. Reverse disassembly procedure and assemble the carrying case.

4-10. Battery Adapter (fig. 1-1)

a. Cleaning. Wipe the battery adapter with a clean, dry cloth.

b. Test. Check battery adapter for continuity. Touch the probes of a multimeter to the contact and the battery case adapter. If continuity is not

established, test each wire of the cable, each terminal and the contact connection for continuity. If malfunction has not been found, refer to figure 6-1 and assure that battery adapter is assembled correctly.

4-11. Receiver and Transmitter Assembly

a. Battery.

(1) *Removal.* Refer to figure 2-1 and remove the battery.

(2) *Cleaning and Inspection.* Refer to paragraph 4-1 for cleaning and inspection of the battery.

(3) *Test.* To test the battery, use a multimeter and place the function switch in the d.c. position. Place the range selector switch on the 50 volt range. Turn detector power selector switch to the intermediate position. Remove transmitter-receiver from case. Check battery voltage by placing negative probe of multimeter on battery tube end terminal and positive probe to ground. Read voltage. If battery voltage is less than 8.5 volts, replace battery.

(4) *Installation.* Refer to figure 2-1 and install battery in the receiver and transmitter assembly.

CAUTION

Do not leave the battery in the receiver and transmitter assembly when the detector set is not in use. The batteries will sometimes corrode, causing damage to the terminals inside the battery housing.

b. Modules.

(1) *Removal.*

(a) Release the two snap fasteners at the sides of the receiver and transmitter assembly

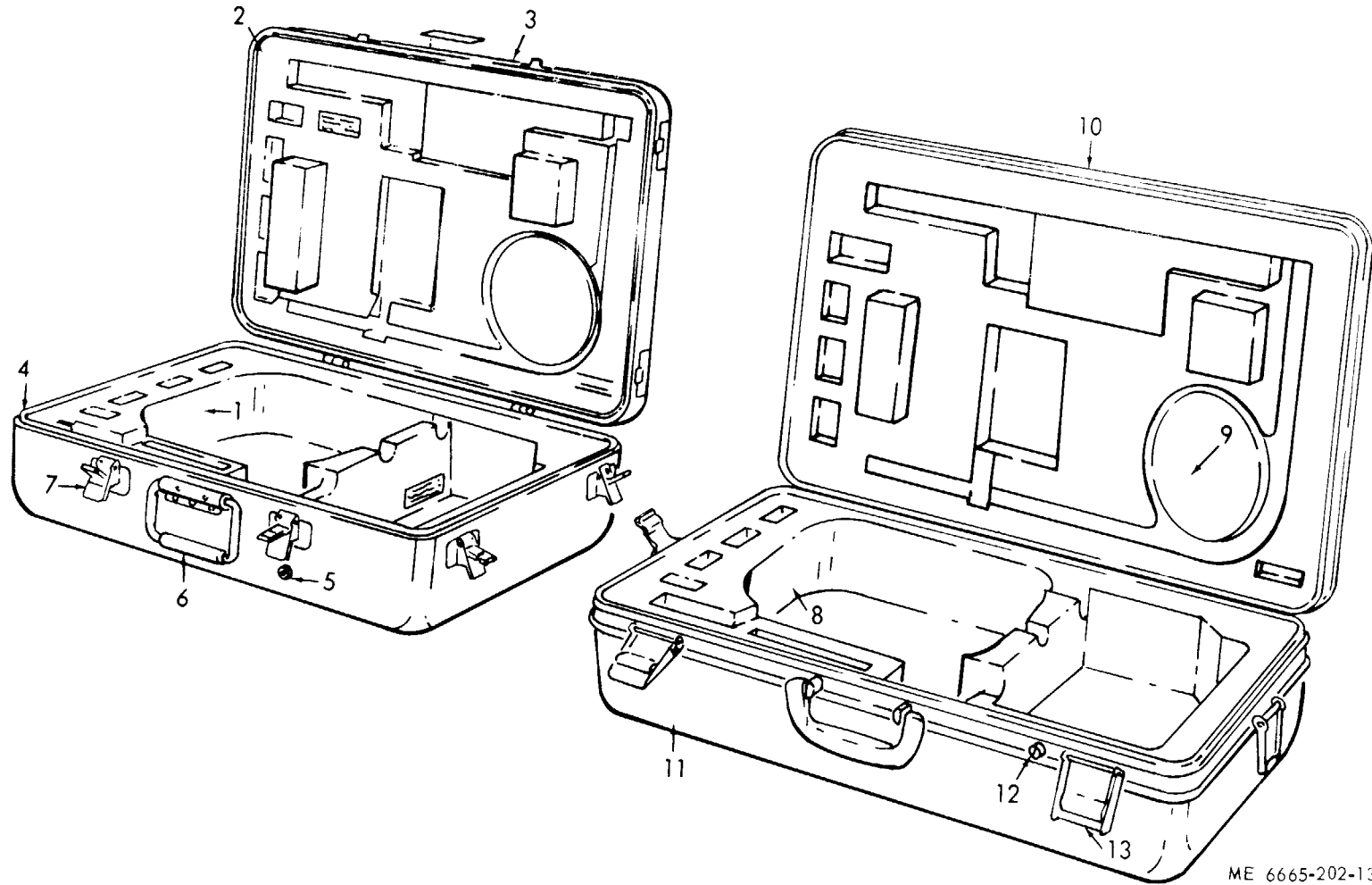

ME 6665-202-13/4-1

Figure 4-1. Carrying case and inserts, disassembly and reassembly.

(fig. 1-1) and slide the housing from the header assembly.

(b) Refer to figure 4-2, and remove the modules.

(2) *Cleaning and Inspection.*

(a) Wipe the modules with a clean, dry, cloth.

(b) Inspect for cracks, breaks, corroded, or bent contact pins.

(c) Replace a damaged or defective module as necessary.

(3) *Installation.*

(a) Refer to figure 4-2 and install the modules.

(b) Slide the housing over the chassis (fig. 5-1) and secure to the header with two snap fasteners at each side of the housing.

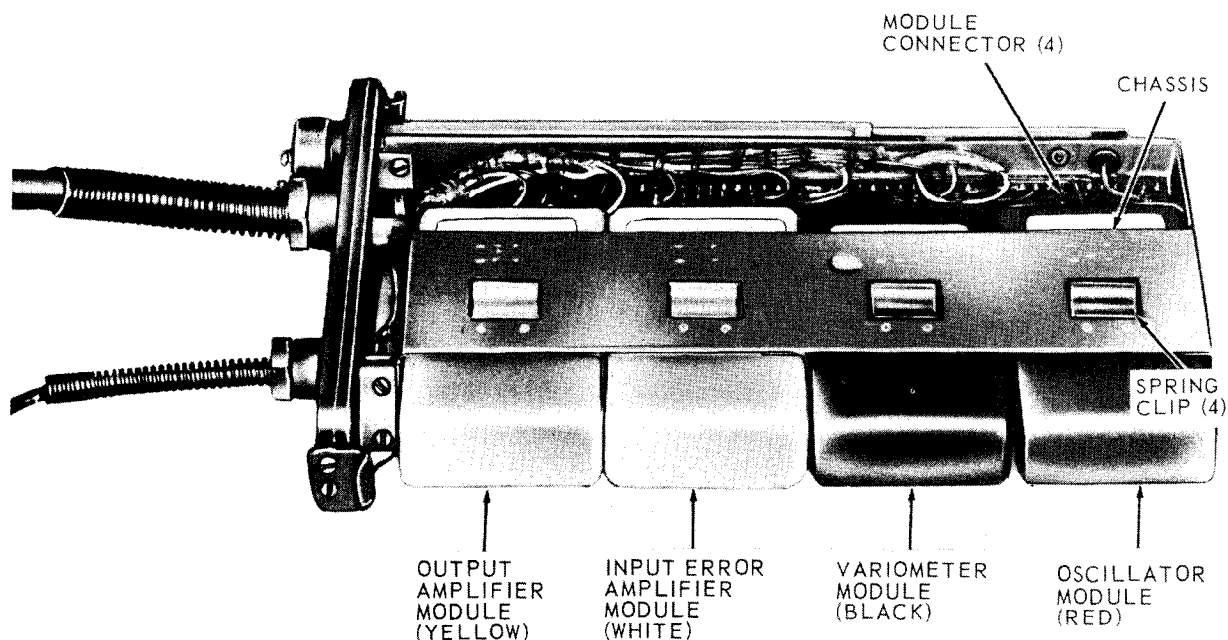

MODULE REMOVAL:

REMOVE MODULE BY GRASPING FIRMLY WITH FINGERS AND PULLING.

CAUTION: AVOID ANGULAR MOVEMENT WHEN REMOVING OR INSTALLING MODULES, BENT OR BROKEN CONTACT PINS MAY RESULT.

MODULE INSTALLATION:

STEP 1. POSITION MODULE IN CHASSIS WITH INDENTED SIDE OF MODULE FACING UPWARD.

NOTE: MODULE LOCATIONS ARE INDICATED BY COLOR CODING OF MODULES AND SPRING CLIPS. ALSO, CONTACT PINS OF EACH MODULE ARE DESIGNED TO FIT ONLY THE CORRESPONDING MODULE CONNECTOR.

STEP 2. CAREFULLY PUSH MODULE FORWARD UNTIL CONTACT PINS MATE WITH MODULE CONNECTOR. (SPRING) CLIP WILL SNAP INTO INDENTATION ON TOP OF MODULE, WHEN MODULE IS PROPERLY INSTALLED.

ME 6665-202-13/4-2

Figure 4-2. Modules, removal and installation.

CHAPTER 5

DIRECT SUPPORT MAINTENANCE INSTRUCTIONS

Section I. REPAIR PARTS AND SPECIAL TOOLS AND EQUIPMENT

5-1. Tools and Equipment

Tools, equipment, and repair parts issued with or authorized for the mine detecting set are listed and illustrated in TM 5-6665-202-23P. An electronic AC RMS voltmeter replaces the vacuum tube voltmeter.

5-2. Special Tools and Equipment

The special tools required to perform direct support

maintenance on the mine detecting set are listed in section III of appendix B.

5-3. Maintenance Repair Parts

Repair parts and equipment are listed and illustrated in the repair parts and special tools list covering direct support maintenance for this equipment in TM 5-6665-202-23P

Section II. TROUBLESHOOTING

5-4. General

a. This section contains troubleshooting information for locating and correcting most of the operating trouble which may develop in the mine detecting set. Each malfunction for an individual component, unit, or system is followed by a list of tests or inspections which will help you to determine probable causes and corrective actions to take. You should perform the tests/inspections and corrective action in the order listed.

b. This manual cannot list all malfunctions that may occur, nor all tests or inspections and corrective actions. If a malfunction is not listed or is not corrected by listed corrective actions, notify depot maintenance personnel.

5-5. Troubleshooting

Refer to chart 5-1 and troubleshoot a malfunctioning mine detector set.

Chart 5-1. Troubleshooting

MALFUNCTION
TEST OR INSPECTION
CORRECTIVE ACTION
<p>1. MINE DETECTOR FAILS TO START WHEN SWITCH IS TURNED ON.</p> <p style="padding-left: 20px;">Step 1. Inspect for loose, corroded, broken or defective battery connections. Clean corroded battery connections, tighten loose, or replace broken battery connections.</p>

Chart 5-1. Troubleshooting-Continued

MALFUNCTION
TEST OR INSPECTION
CORRECTIVE ACTION
<p>Step 2. Check for defective switch. Test switch for continuity while in the ON position. Replace switch if test indicates an "open" circuit.</p> <p>Step 3. Check for defective terminal board. Remove modules end test terminal board. Replace a defective terminal board.</p>
<p>2. HEADSET DOES NOT GIVE SATISFACTORY SIGNAL</p> <p>Step 1. Check for defective headset. Test headset and replace if either or both earphones are defective.</p> <p>Step 2. Check for defective detector head. Test transmitter coil and receiver coil located in detector head and replace coils if defective.</p> <p>Step 3. Check for defective terminal board. Remove modules end test terminal board. Replace a defective terminal board.</p>
<p>3. SET CUTS OFF AND ON DURING OPERATION</p> <p>Step 1. Check for loose connection at detector head. Tighten loose or repair broken connection at detector head.</p> <p>Step 2. Check for defective detector head. Test transmitter coil and receiver coil located in detector head and replace coils if defective.</p> <p>Step 3. Check for defective terminal board. Remove modules and test terminal board. Replace a defective terminal board.</p>

MALFUNCTION TEST OR INSPECTION CORRECTIVE ACTION	MALFUNCTION TEST OR INSPECTION CORRECTIVE ACTION
<p>3. SET CUTS OFF AND ON DURING OPERATION - CONTINUED</p> <p>Step 4. Check for defective headset. Test headset and replace if either or both earphones are defective.</p> <p>Step 5. Check for defective capacitor. Remove and test capacitor. Replace a defective capacitor.</p> <p>Step 6. Check for defective power selector switch. Test power selector switch for continuity while in the "ON" position. Replace switch if test indicates an "open" circuit.</p> <p>4. SIGNAL DOES NOT INCREASE AS DETECTOR HEAD COMES CLOSER TO METAL OBJECT.</p> <p>Step 1. Check for defective detector head. Test transmitter coil and receiver coil located in detector head and replace coils if defective.</p> <p>Step 2. Check for defective terminal board. Remove modules and test terminal board. Replace a defective terminal board.</p>	<p>5. PROPER ADJUSTMENT CANNOT BE OBTAINED WITH FINE X CONTROL</p> <p>Step 1. Check for defective Fine X control. Remove Fine X control resistor (19, fig. 6-5) and test. Replace a defective Fine X control resistor.</p> <p>Step 2. Check for defective terminal board. Remove modules and test terminal board. Replace a defective terminal board.</p> <p>6. PROPER ADJUSTMENT CANNOT BE OBTAINED WITH FINE R CONTROL.</p> <p>Step 1. Check for defective Fine R control resistor. Remove Fine R control resistor (16, fig. 6-5) and test. Replace a defective Fine R control resistor.</p> <p>Step 2. Check for defective terminal board. Remove modules and test terminal board. Replace terminal board if defective.</p> <p>7. SET FAILS SENSITIVITY TEST (Para 2-10, Fig 2-6)</p> <p>Step 1. Check battery; replace if necessary.</p> <p>Step 2. Check variometer phasing adjustment using the phasing fixture and magnetite tube.</p>

Section III. REMOVAL AND INSTALLATION OF MAJOR COMPONENTS AND AUXILIARIES

5-6. Headset

a. Removal.

(1) Remove the housing from the transmitter (para 4-11b).

(2) Refer to figure 5-1 and remove the headset.

b. Installation.

(1) Refer to figure 5-1 and install the headset.

(2) Install the housing on the transmitter (para 4-11b).

5-7. Control Box

a. Removal. Refer to figure 5-2 and remove the control box.

b. Installation. Refer to figure 5-2 and install the control box.

5-8. Detector Head and Balance Coil Assembly

a. Removal. Refer to figure 5-3 and remove the detector head and balance coil assembly.

b. Installation. Refer to figure 5-3 and install the detector head and balance coil assembly.

5-9. Modules

a. Removal. Refer to paragraph 4-11b and remove the four modules from the transmitter and receiver assembly.

b. Test. Refer to Table 5-1 and perform the point-to-point test applicable to each of the four modules. Replace a defective module. When performing these tests, use an electronic AC RMS Voltmeter (1-B, Appendix C) and Test Leads (2-B, Appendix C).

c. Installation. Refer to paragraph 4-11b and install the four modules in the transmitter and receiver assembly.

d. Variometer Phasing Adjustment. Adjust the detecting set with the detection head positioned on the phasing fixture (figure 5-4). The phasing fixture will permit optimizing the phase adjustment so that the presence of magnetite will produce the smallest background signal possible. The phasing fixture should be used whenever a variometer module not previously phased to the particular detector is inserted in the detector. The phasing fixture and detector head should rest on a non-metallic table or stand whose construction can be of plastic or wood except there can be no metal fasteners used. Keep metallic objects (watches, rings, belt buckles, tools, metal lab stools, etc.) away from the detection head at least 2 1/2 feet in all directions. A non-metallic alignment tool (plastic wand with a small metal blade mounted in the end) should be used for any adjustments. The following steps will enable the phase adjustment to be properly made.

NOTE: TAG AND DISCONNECT ELECTRICAL LEADS AS NECESSARY.

NOTE: REMOVE WASHER AND PREFORMED PACKING FROM HEADER AFTER REMOVAL OF BUSHING.

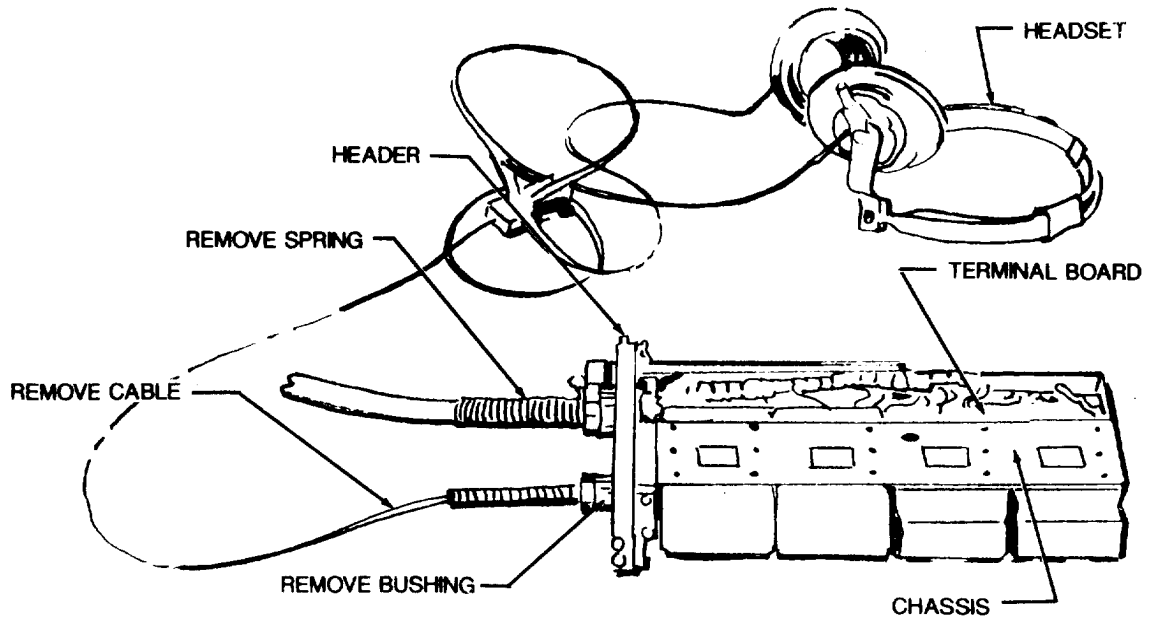

Figure 5-1. Headset, removal and installation.

Table 5-1. Modules Point-to-Point Test

At Input Error Amplifier Module (White)

Terminal No.	Description
3	Output of X control DC voltage (variable-1.25 to 0 volts depending on position of X control).
1&2	Output of input amplifier, two voltages AC and DC-DC voltage, same as that at pin no. 3
11	Ground
5	Input to the A1 amplifier AC signal.
7	AC Ground.
10	R Control feedback voltage AC signal.
6	-6.3 Volts regulated DC.
4	10 Volts unregulated DC or whatever battery voltage is.
12	Output to output amplifier. The signal will be lower than that at pins 1 and 2 AC signal.

NOTE

Pins 1 and 2 have an AC and DC voltage. DC voltage should be equal to that of DC voltage at pin 3. Pin 5 and 10 is where phase detecting is accomplished.

At Variometer Module (Black)

2	Approximately AC ground (.25 OHMS) one side of driving voltage for oscillator.
1	90 degrees Out of phase signal used for phase detection.
7	6.2 volts DC regulated.
3	One side of phase adjusting resistor in variometer.
4	Other side of phase adjusting resistor in variometer end return path to ground.

Table 5-1. Modules Point-to-Point Test- Continued

Terminal No.

5	AC signal going to receiver coil.
6	AC ground.
9	AC signal connects input amplifier.
8	Ground.
11 & 12	Output of input amplifier and is AC and DC component.

A3 Output Amplifier Module (Yellow with Black Stripe)

1	DC end AC voltages.
3	AC Feed back loop. It determines gain of output amplifier.
9	Input voltage from battery.
5	Output to earphone AC signal.
4	Ground
7	Regulated 6.2 volts DC.
2	Unregulated 10 volts DC same as battery voltage safety diode which prevents a damage in case batteries are installed improperly.
8	DC output to X control -1.26 volts approximately.

A4 Oscillator Module (Red)

7	Regulated -6.3 volts DC.
5	Ground
6	10 volts unregulated DC actual 9.6 (You have a loss because voltage has passed thru the protective diode).
2 & 10	One of the outputs from oscillator (in phase) 250 to 360 millivolts.
12	Output (90 degrees out of phase) AC signal 126 to 175 millivolts (voltages taken at a null condition).

NOTE: REMOVE DOWEL PIN FROM EXTENSION HANDLE AFTER REMOVAL OF CONTROL BOX.

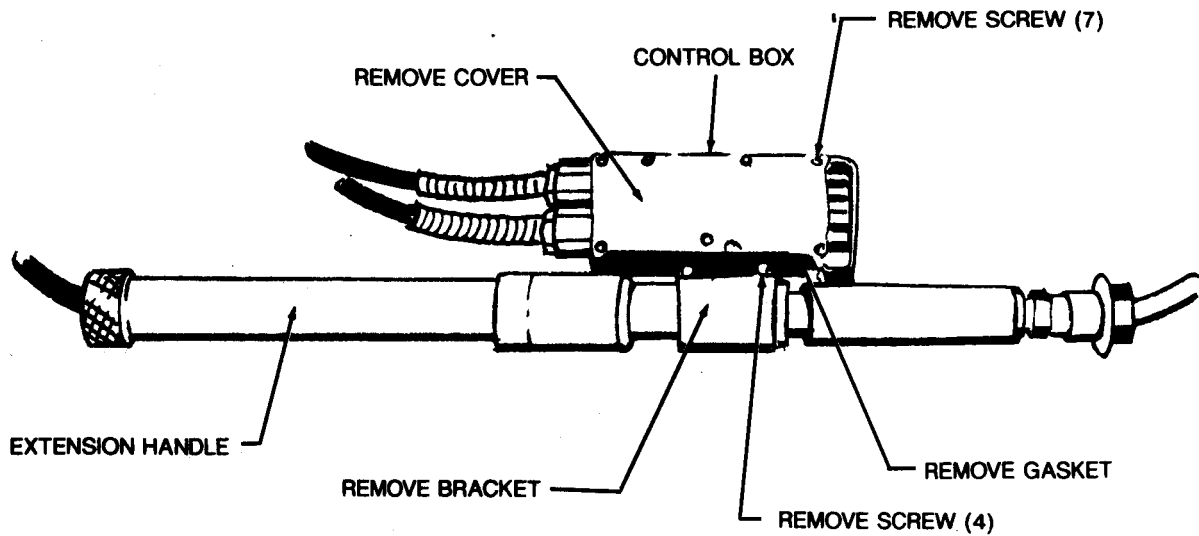

A. BRACKET, COVER, AND CONTROL BOX.

NOTE: TAG AND DISCONNECT ELECTRICAL LEADS AS NECESSARY.

NOTE: REMOVE WASHER AND PREFORMED PACKING FROM EACH CABLE AFTER REMOVAL OF CABLE.

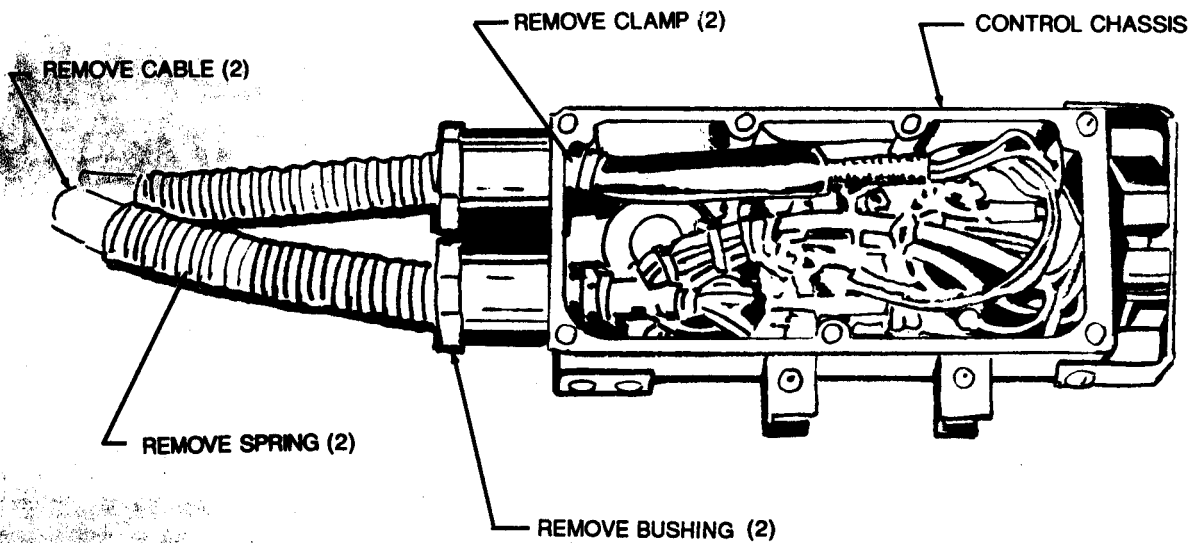

B. CABLES AND FITTINGS.

Figure 5-2. Control box, removal and installation.

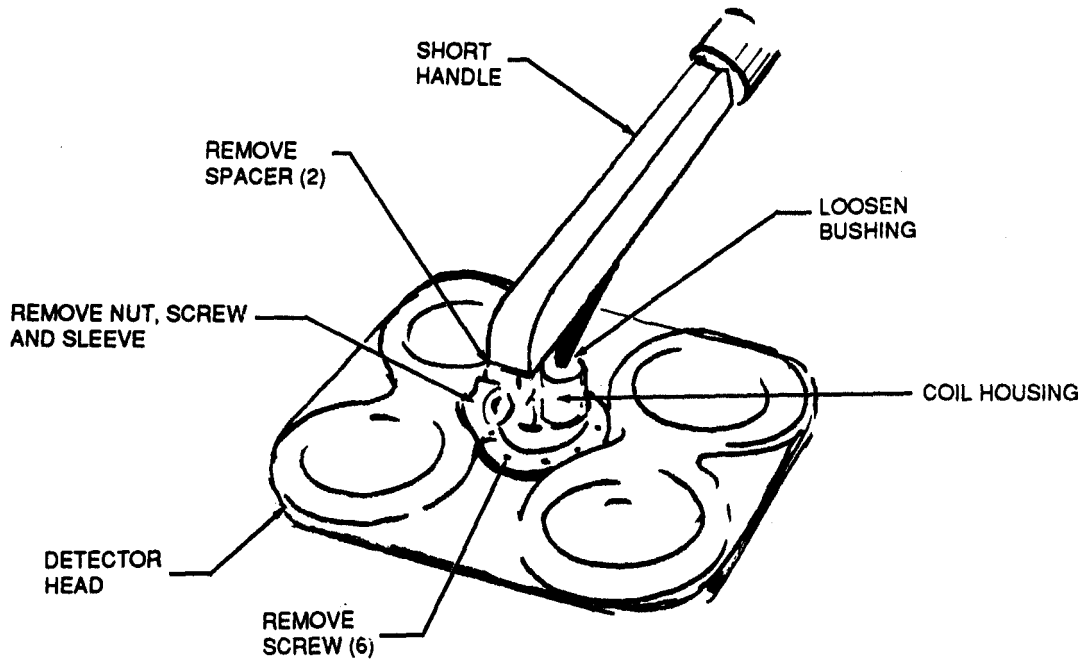

A. SHORT HANDLE AND COIL HOUSING.

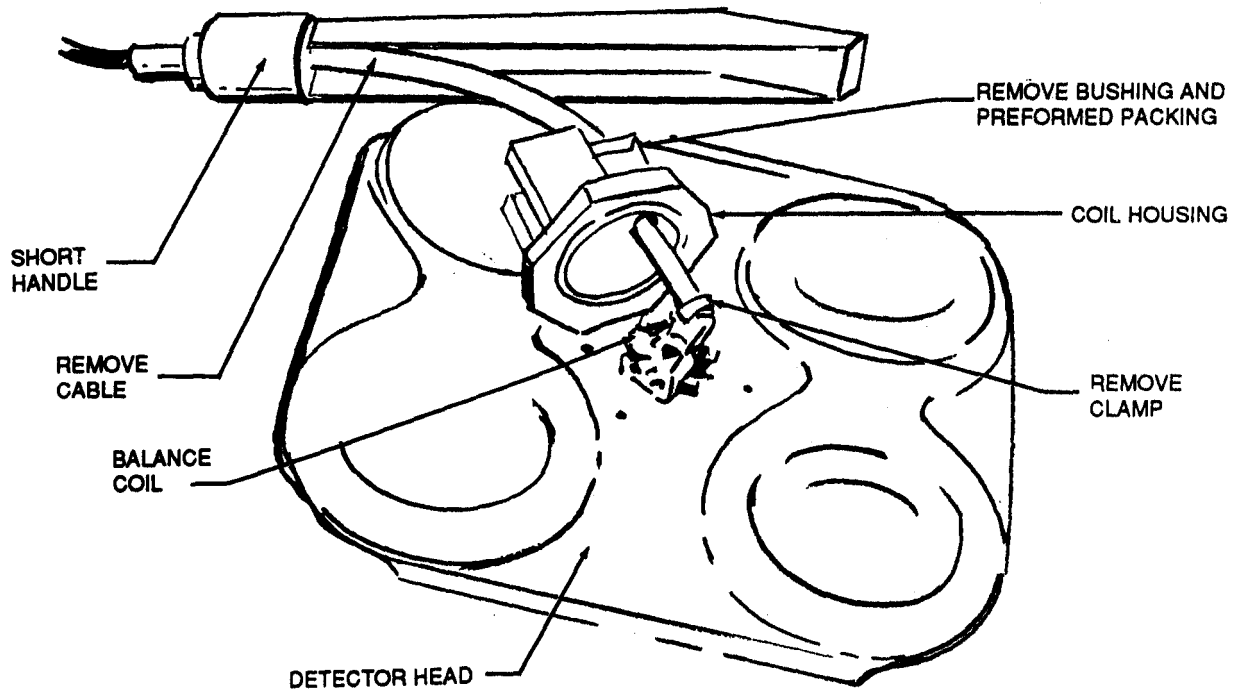

NOTE: TAG AND DISCONNECT ELECTRICAL LEADS AS NECESSARY.
 NOTE: SLIDE COIL HOUSING UP CABLE FOR ACCESS TO BALANCE COIL.

Figure 5-3. Short handle, detector head and balance coil, removal and installation.

(1) Disconnect the collapsed long handle from the short handle. Slide this unit along the cable at least 2.5 feet away from the detector head (placement near the transmitter/receiver package).

(2) Place detector head on the phasing fixture (figure 5-4).

(3) Position the short handle on the detector head to an angle of 46 degrees with the horizontal.

(4) Remove the transmitter/receiver cover and connect the RMS Voltmeter to point E4 and E16 (see figure 5-5).

(5) Adjust the "R" control (ten turn potentiometer) to the center of its rotation (five turns from either end of its rotation) and align the index marks.

(6) Adjust the "X" control (one turn potentiometer) to the center of its rotation and align the index marks.

(7) Insure that the magnetite tube is not positioned in the phasing fixture.

(8) Turn the detector on and set the selector switch to the intermediate (INT) position. The RMS meter will read up scale. Adjust the meter sensitivity for a mid-scale reading.

(9) Using the non-metallic tuning wand, adjust the variometer control (A-2 module) (see figure 5-5) to obtain a null (minimum AC millivolts) as indicated on the RMS meter. Reduce meter sensitivity as necessary to achieve the lowest meter reading.

NOTE

The initial measurement values (step 10 and step 11) will vary from detector to detector. The number of measurements/adjustment steps will vary from detector to detector and will depend upon the right/left balance point. The end result of the balance between the right (step 10) and the left (step 11) are important factors, not the numerical values obtained.

(10) Place the magnetite tube on the right side of the phasing fixture, (right side is identified by the "white dot" on the detector head). Record the reading indicated on the meter.

(11) Place the magnetite tube on the left side of the phasing fixture. Record the RMS meter reading.

(12) Subtract the lesser meter reading from the larger one (step 10 & step 11) and divide the result by two.

(13) Place the magnetite tube on the right side.

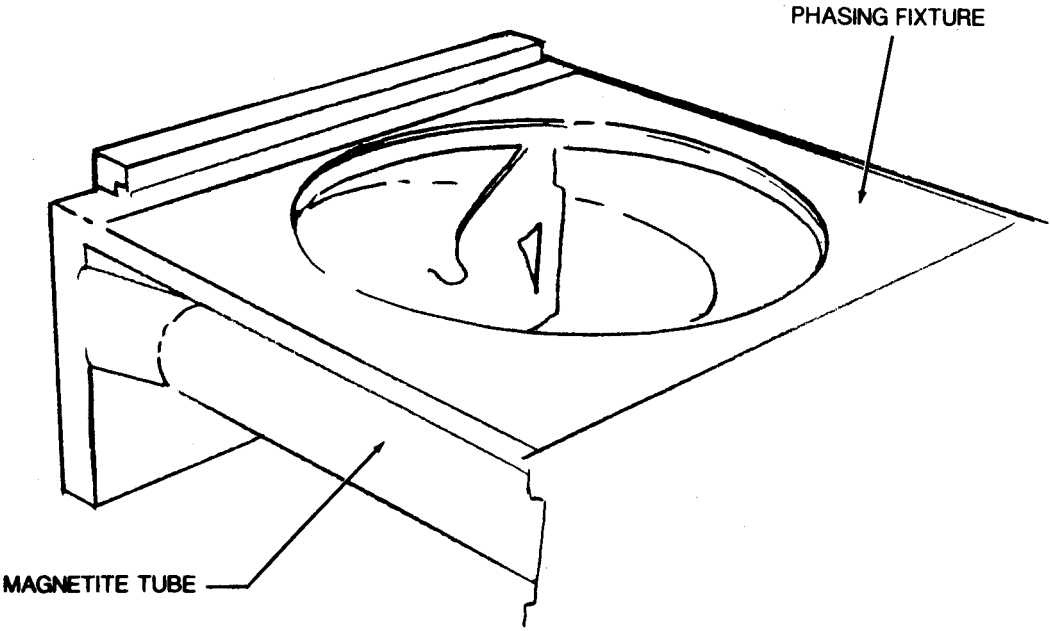

A. PHASING FIXTURE

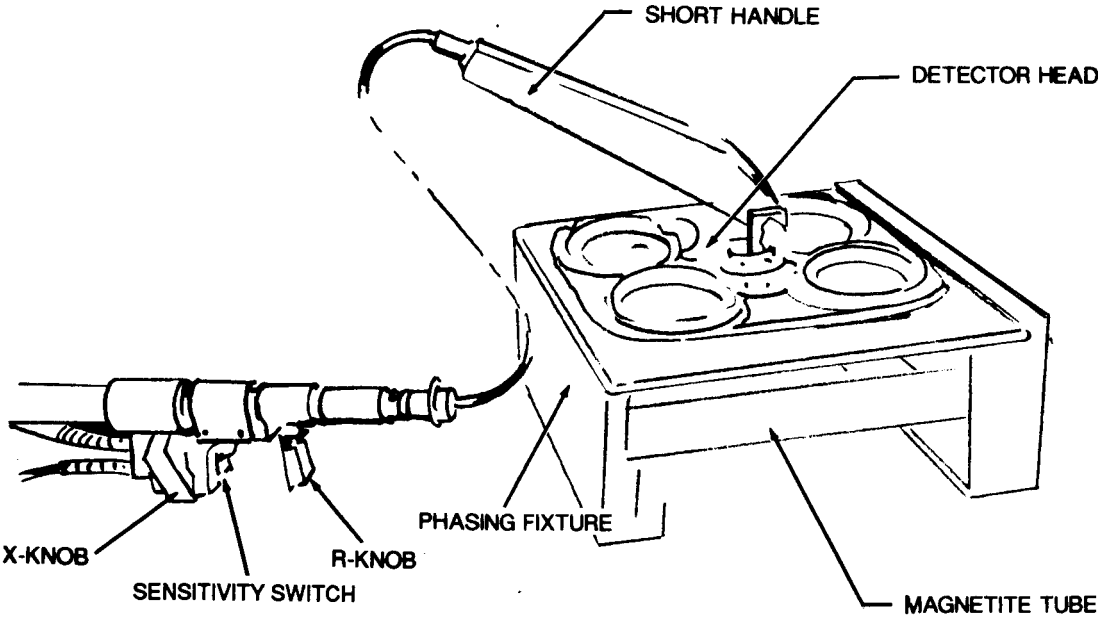

B. DETECTOR INSTALLED ON PHASING FIXTURE

Figure 5-4. Variometer phasing adjustment.

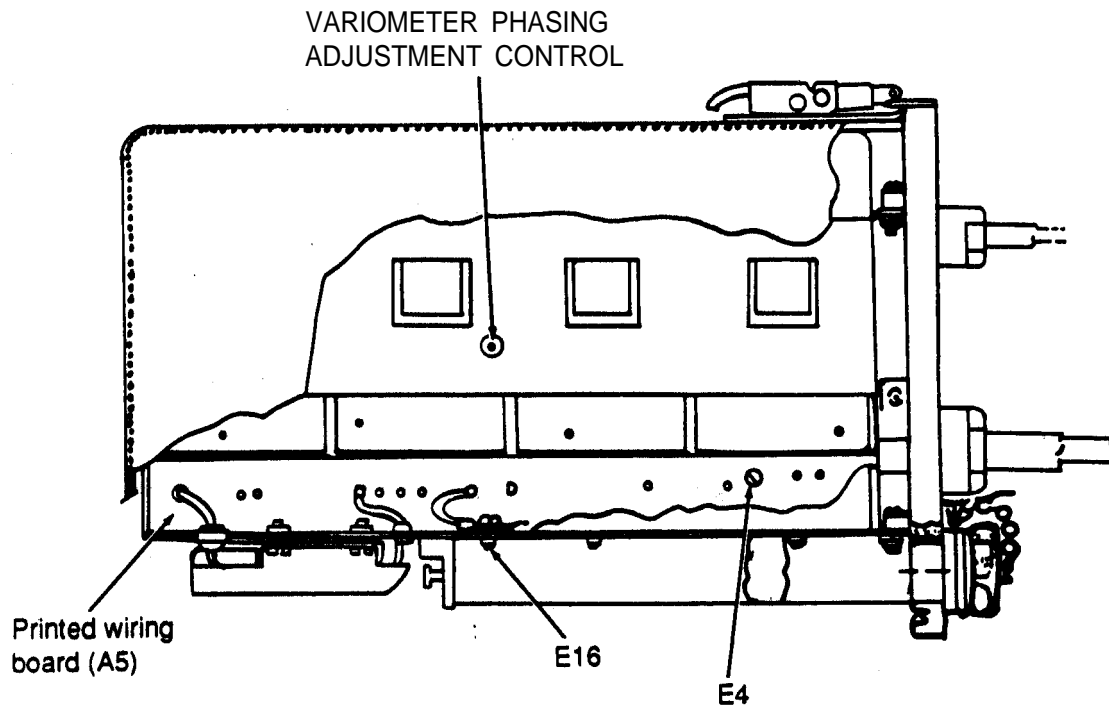

Figure 5-5. Transmitter/Receiver Assembly

(14) If the right side reading is HIGHER than the left side, SUBTRACT the result obtained in step 12 from the reading recorded in step 10 and adjust the variometer control in a CLOCKWISE direction to obtain the new value. If the right side reading is LOWER than the left side, ADD the result obtained in step 12 to the reading recorded in step 10 and adjust the variometer control in a COUNTERCLOCKWISE direction to obtain the new value.

(15) Remove the magnetite tube.

(16) Alternately adjust the "X" and "R" controls until a minimum null is reached as indicated on the RMS meter.

(17) Repeat steps 10 through 16 until the difference between the right and the left side is equal to or less than + or -5 percent of each other.

(18) When the conditions in step 17 are met, the control settings should be as follows: the "X" control setting should be very close to the center position (index marks aligned) and the "R" control should be plus or minus two turns from the center position as stated in step 5. There should be a good null present (less than 7 mv).

(19) If "R" control does not meet the requirements of step 18, center the "R" control as per step 5 and adjust R6 (inside the control box) for a good null. A minor adjustment of the "R" control should restore the "less than 7 mv" requirement of step 18.

(2) Failure to meet the conditions of step 18 indicates a defective head and or A-2 variometer module. Replace either and repeat the complete procedure.

CHAPTER 6

REPAIR OF MINE DETECTOR SET

6-1. Battery Adapter

a. Removal. Refer to figure 2-9 and remove the battery adapter.

b. Disassembly. Refer to figure 6-1 and disassemble the battery adapter.

c. Cleaning, Inspection, and Repair.

(1) Clean the contacts, terminals, and cable with a clean, dry cloth. Clean all other parts with cleaning solvent (Fed. Spec. P-D-680) and dry thoroughly.

(2) Inspect for cracks, breaks, dents, rust, damaged threaded areas, or other defects.

(3) Replace damaged or deteriorated contacts, terminals, or cable. Replace components which have damaged threaded areas. Replace springs that are bent, broken or which have lost tension. Replace defective bushings and packing as necessary.

d. Reassembly. Refer to figure 6-1 and reassemble the battery adapter.

e. Installation. Refer to figure 2-9 and install the battery adapter.

6-2. Receiver and Transmitter Assembly

a. General. The receiver and transmitter assembly consists of a header, cover, four modules which contain sealed circuitry, battery tube, terminal board, capacitor, cables and electrical leads, and the chassis to which most of the components are mounted. The item is designed in a compact manner for ease of handling and transporting.

b. Header.

(1) *Removal.*

(a) Remove the modules (para 4-11b).

(b) Remove the headset (para 5-6).

(c) Refer to figure 6-2 and remove the header.

(2) *Cleaning, inspection and repair.*

(a) Wipe the headset with a clean, dry cloth.

(b) Inspect for breaks, cracks, rust, loose, or missing mounting hardware, or other damage.

(c) Replace a damaged or defective header as necessary.

(3) *Installation.*

(a) Refer to figure 6-2 and install the header.

(b) Install the headset (para 5-6).

(c) Install the modules (para 4-11b).

c. Terminal Board.

(1) *General.* The terminal board consists of a printed circuit board and four module connectors. A rectangular spacer separates the terminal board from the chassis.

(2) *Test.* Refer to tables 6-1 and 6-2 and perform the point-to-point voltage and resistance checks with terminal board installed but with modules removed. If terminal board is defective, remove and replace.

(3) *Removal.*

(a) Remove the modules (para 4-11b).

(b) Refer to figure 6-3 and remove the terminal board.

(4) *Cleaning, inspection, and repair.*

(a) Wipe the terminal board with a clean, dry cloth. Clean corrosion from terminals and electrical components with an approved corrosion removing compound (FSN 6850-550-5565, MIL-C-14460A). Clean electrical components with electrical part cleaner (FSN 6850-664-5641).

(b) Inspect for breaks, cracks, corrosion, or other defects.

(c) Replace a damaged or defective terminal board m necessary.

(5) *Installation.*

(a) Refer to figure 6-3 and install the terminal board.

(b) Install the modules (para 4-11b)

d. Capacitor.

(1) *Removal.*

(a) Remove the housing (para 4-11b)

(b) Refer to figure 6-4 and remove the capacitor.

Table 6-1. Resistance Measurements of Receiver and Transmitter Assembly
A5 Printed Circuit Board

Terminal No.	Measurement made to	Multimeter resistance reading	Ohmmeter setting
1	Ground	Infinity	RX10,000
2	Ground	900 to 1100	RX100
2	7	0-1000	RX100 (Resistance variable by "X" variable resistor on detector's control box)
3	Ground	Infinity	RX10,000
4	Ground	150 to 300	RX10
5	Ground	Infinity	RX10,000 (Detector's Control Knob in OFF or LO positions)
5	Ground	2,000	RX100 (Detector's control knob in INT position)
5	Ground	0.33	RX1 (Detector's control knob in HI position)
6	Ground	Infinity	RX10,000
6	9	1,000	RX100
6	11	1,000	RX100
6	12	1,000	RX100
7	Ground	0-1000 ± 10%	RX100 (Resistance variable by "X" resistor or detector's control box)
8	Ground	0 (Continuity)	RX1
9	Ground	Infinity	RX10,000
9	10	50	RX1
9	11	120	RX10
9	12	125	RX10
10	Ground	Infinity	RX10,000
11	Ground	Infinity	RX10,000
11	12	3.5	RX1
12	Ground	Infinity	RX10,000

- NOTE**
- All resistance values are in ohms with a tolerance of plus (+) or minus (-) 5%.
 - All resistance measurements are made with A1, A2, A3, and A4 modules removed from Receiver and Transmitter.
 - All terminals are located on A5 printed circuit board.

Table 6-2. Voltage Measurements of Receiver and Transmitter
Assembly A5 Printed Circuit Board

Terminal No.	Measurement made to	Voltage readings	Remarks
1	Ground	0.0 VDC	Power selector switch on the detector's control box in the OFF position
1	Ground	-10.6 VDC	Power selector switch on the detector's control box in LO, INT, and HI positions.
2	Ground	-1.25 VDC	
4	Ground	See note 4	
6	Ground	-0.9 VDC	
6	9	0.0 volts	No reading AC or DC.
6	11	0.0 volts	No reading AC or DC.
6	12	2.8 VAC	
7	Ground	0 to -1.25 VDC	Voltage variable by "X" variable resistor on the detector's control box.
8	Ground		Terminal 8 is grounded.
9	Ground	-0.9 VDC	
9	10	0 volts	No reading AC or DC.
9	11	0 volts	No reading AC or DC.
9	12	3.0 VAC	
10	Ground	-0.9 VDC	
11	12	3.0 VAC	
12	Ground	-0.9 VDC & 3.0 VAC	
14	Ground	-6.3 VDC	
13	Ground	-10.0 VDC	

- NOTE**
- Voltage measurements are with the mine detector in a null or balance condition.
 - The above voltage values will vary depending on the battery output voltage.
 - All terminals are located on A5 printed circuit board.
 - With mine detector balanced and search head 3 feet from metallic objects the following voltages should be obtained:
 - High sensitivity position - less than 15 MVAC RMS.
 - Intermediate sensitivity position - less than 5 MVAC RMS.
 - Low sensitivity position - less than 1.5 MVAC RMS.

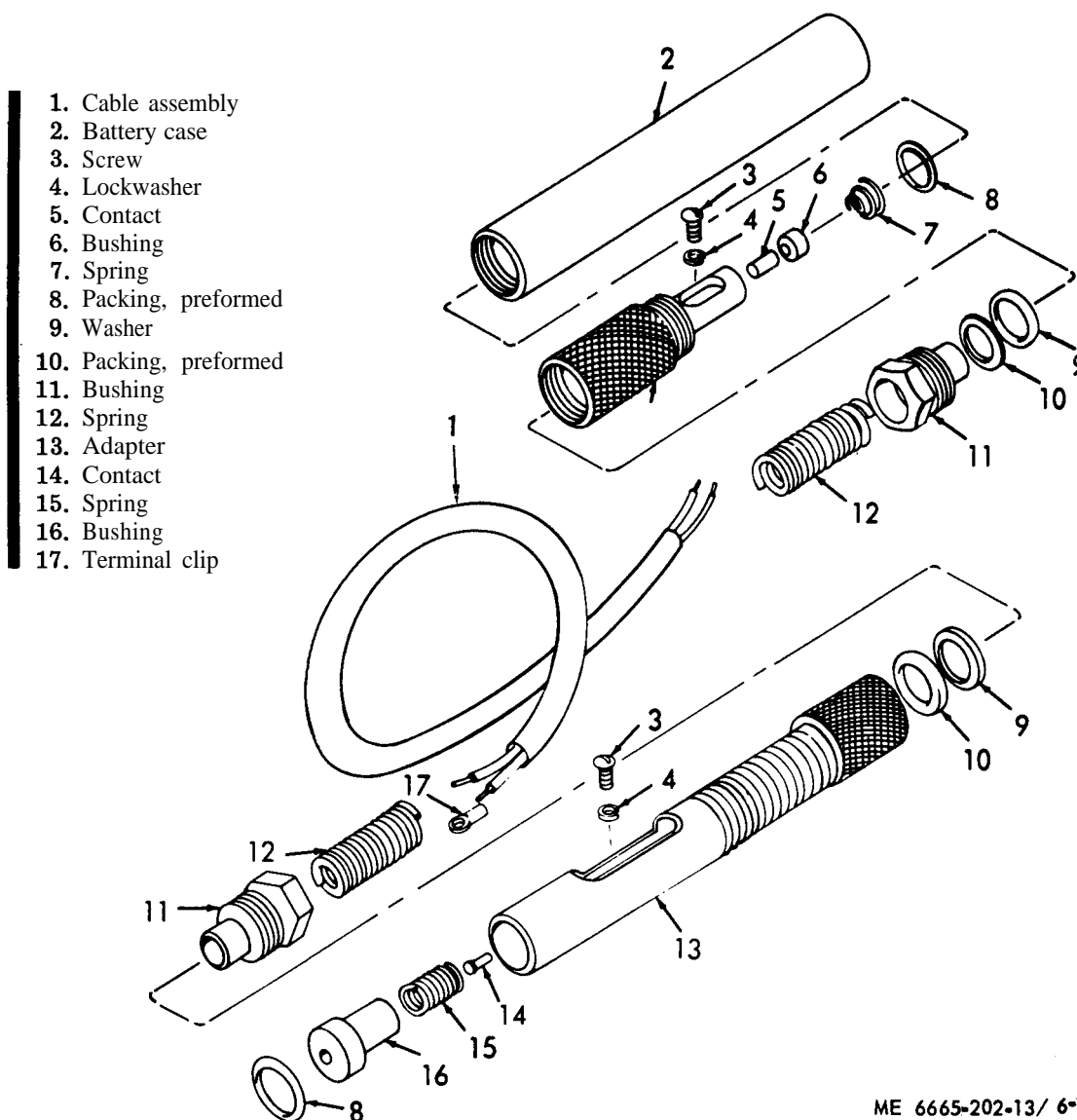

ME 6665-202-13/ 6*1

Figure 6-1. Battery adapter, disassembly and reassembly.

(2) Cleaning, inspection, and repair.

(a) Wipe the capacitor with a clean, dry cloth.

(b) Inspect for breaks, corrosion, or other damaged connections.

(c) Replace a defective capacitor as necessary.

(3) *Testing the capacitor.* Test the capacitor with a suitable capacitor tester. The capacitance should be 1.43 microfarad at 100 VDC.

(4) *Installation.* Reverse removal procedure and install the capacitor in the transmitter and receiver assembly.

e. Chassis.**(1) Removal.**

(a) Remove the capacitor (subpara d).

(b) Remove the terminal board (subpara c).

(c) Remove the header (subpara b).

(2) Cleaning, inspection and repair.

(a) Wipe the chassis with a clean, dry cloth.

(b) Inspect for breaks, cracks, bends, corrosion, damaged threaded areas, and other defects.

(c) Replace a damaged or defective chassis as necessary.

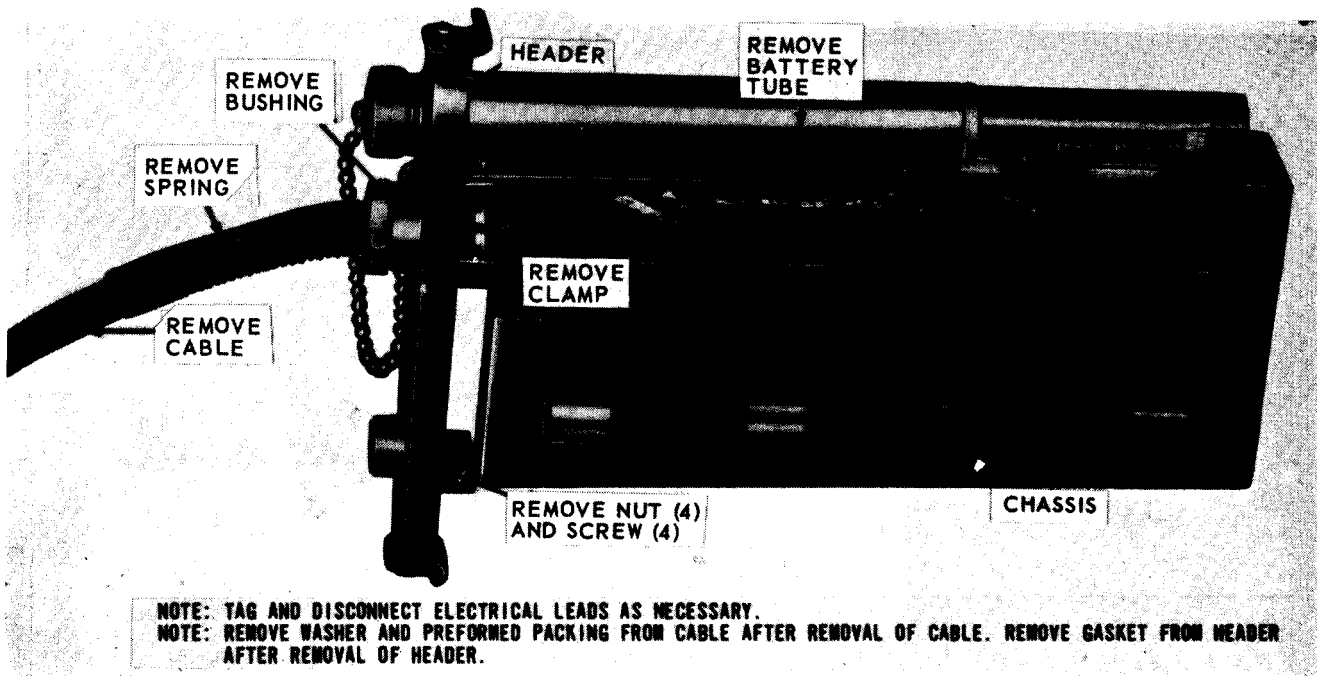

ME 3655-202-13/6-2

Figure 6-2. Header, removal and installation.

NOTE: TAG AND DISCONNECT ELECTRICAL LEADS AS NECESSARY.

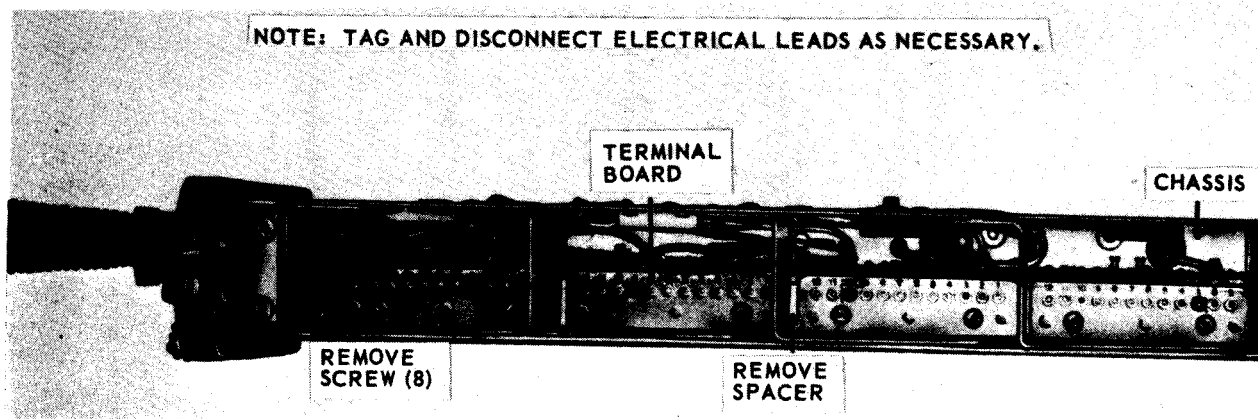

ME 3655-202-13/6-3

Figure 6-3. Terminal board, removal and installation.

NOTE: TAG AND DISCONNECT ELECTRICAL LEADS AS NECESSARY.

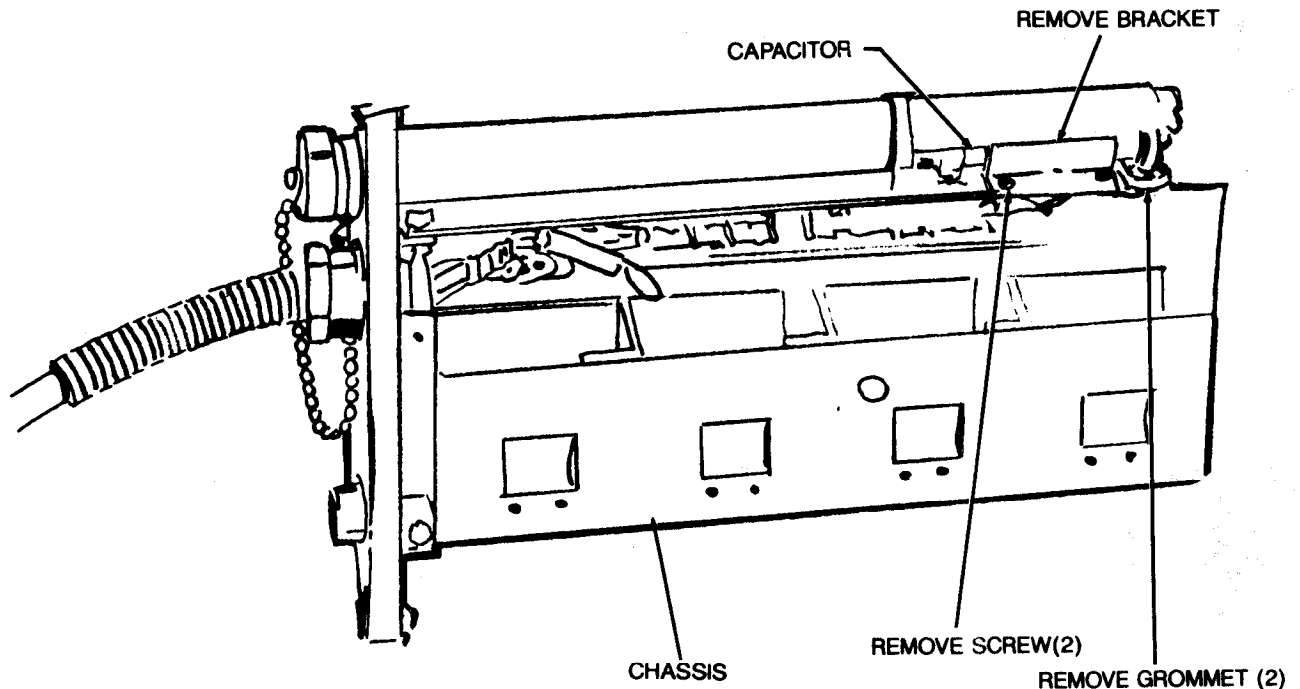

Figure 6-4. Capacitor, removal and installation.

(3) *Installation.*

(a) Install the header (subpara b).

(b) Install the terminal board (subpara c).

(c) Install the capacitor (subpara d).

f. *Testing for Correct Phasing of Module.*

(1) Place search head on mine detector phasing fixture (FSN 6665-999-7253) (fig. 5-4).

(2) Balance mine detector to less than 5 MVAC RMS in the intermediate sensitivity position. Output voltage is measured on A5 board (FO-1) between terminal 4 and ground.

(3) Place magnetite tube in slots on right side of phasing fixture and measure voltage at terminal 4.

(4) Repeat measurement with magnetite on left side of phasing fixture.

(5) Voltage measurements should be less than 400 MVAC and within + or - 5 percent of each other.

(6) Adjust screw in variometer to obtain correct phasing if necessary.

g. *Testing for Detector sensitivity.*

(1) Balance the mine detector with search head at least 3 feet from metallic objects using the "R" and "X" controls. The output voltages measured at terminal 4 on A5 board are as follows.

(a) *High sensitivity position* - less than 15 MVAC RMS.

(b) *Intermediate sensitivity position* - less than 5 MVAC RMS.

(c) *Low sensitivity position* - less than 1.5 MVAC RMS.

(2) Place test pin (FSN 6665-893-0023) in receiver coil recess on right side of search head. Measure voltage at terminal 4. Repeat measurement with test pin on left side of search head. The following output voltages should be obtained:

(a) *High sensitivity* - 325 MVAC RMS plus or minus 120 MVAC RMS above any balance level less than 15 MVAC RMS.

(b) *Intermediate sensitivity* - 75 MVAC RMS plus or minus 28 MVAC RMS above any balance of less than 5 MVAC RMS.

(c) *Low sensitivity* - 19 MVAC RMS or minus 7 MVAC RMS above any balance level of less than 1.5 MVAC RMS.

6-3. Headset Assembly

a. *Removal.* Refer to figure 5-1 and remove the headset assembly.

b. *Cleaning.* Wipe the headset with a clean, dry cloth.

c. *Inspection.* Inspect headset assembly for breaks, cracks, deteriorated cushions, broken, cut, or corroded electrical leads and terminals.

d. Testing and Repair. Test headset by removing lead from terminal no. 4 on A5 Board (Receiver transmitter assy). Connect ohmmeter to removed lead and ground. An approximate resistance reading of 150 to 300 ohms should be obtained. Place headset to ear and touch multimeter lead to disconnected headset lead. A distinct click should be heard in each ear phone if headset is functioning properly. If there is no indication in the headset, or 150 to 300 ohms is not indicated on the multimeter, the headset is defective and must be replaced.

NOTE

Audio Sears model headset is 160 ohms and Roanwell model headset is 300 ohms.

NOTE

Perform the above test in the same manner on both ear pieces. If one earpiece is operative and the other one is defective, the complete earphone assembly must still be replaced.

e. Installation. Refer to figure 5-1 and install the headset assembly.

6-4. Control Box

a. Disassembly. Disassemble the control box in the order of numerical sequence as illustrated by figure 6-5.

b. Cleaning, Inspection and Repair.

(1) Clean all metal parts with an approved cleaning solvent and dry thoroughly. Clean terminals and contacts with a clean dry cloth. Clean variable resistors with electrical control cleaner (FSN 6850-664-5641). Wipe all plastic and fiber components with a clean, dry cloth.

CAUTION

When cleaning components with cleaning solvents, do not allow the solvents to come in contact with the plastic components of the control, as most cleaning fluids are harmful to plastics.

WARNING

Avoid prolonged breathing of cleaning solvents. If it becomes necessary to breath any amount of solvents ventilate the area as much as possible. Prolonged breathing of solvents may be harmful and injurious to health.

(2) Inspect resistors and terminal connections for breaks, corrosion, or other defects. Inspect control chassis for breaks, cracks, damaged threaded areas, or other defects. Inspect knob covers for breaks, cracks, or other defects. Inspect knobs for chips, nicks, scratches, damaged

threads in setscrew hole, or other defects. Inspect variable resistors and control switch for proper operation when shaft is turned.

(3) Replace all damaged or defective components.

c. Reassembly. Reassemble the control box in the reverse order of numerical sequence as illustrated in figure 6-5.

d. Testing.

(1) *Fixed resistors.* Test the fixed resistors (1, fig. 6-5). The resistance reading should be between 1,995 and 2,005 ohms. If resistance reading is other than specified above, the resistor is defective and must be replaced.

(2) Test fixed resistor (3, fig. 6-5). The resistance reading should be between 78 and 86 ohms. If the resistance reading is other than specified above, the resistor is defective and must be replaced.

(3) Test fixed resistor (7, fig. 6-5). The resistance reading should be between 4,257 to 4,343 ohms. If the resistance reading is other than specified above, the resistor is defective and must be replaced.

(4) Test fixed resistor (9, fig. 6-5). The resistance reading should be between 2,980 and 3,040 ohms, if the resistance reading is other than specified above, the resistor is defective and must be replaced.

(5) To test the variable resistor (8, fig. 6-5), rotate the screw (located in the end of the resistor) clockwise for maximum resistance and counterclockwise for minimum resistance. Values of resistance should vary from 0 to 2,000 ohms. If no reading is obtained or the value indicated on the meter is above 2,000 ohms, the resistor is defective and must be replaced. Test total resistance with a Wheatstone Bridge. Disconnect yellow lead of resistor on TB1-1 and connect multimeter to TB1-6 and the disconnected yellow lead in order to make this test.

(6) Test variable resistor (16, fig. 6-5). Resistance should read from 0 to 1100 ohms. If resistance reads above 1,100 ohms or no reading is obtained as the resistor shaft is rotated in either direction, the resistor is defective and must be replaced. Test total resistance with a Wheatstone Bridge. In order to test resistor, disconnect yellow and white lead from terminal board A5 terminal no. 7. Connect multimeter to ground and disconnect lead.

(7) Test variable resistor (19, fig. 6-5). Resistance should read from 0 to 525 ohms as resistor shaft is rotated. If resistance reads above 525 ohms or no reading is obtained as shaft is

NOTE: BEFORE DISASSEMBLY, TURN ALL CONTROL KNOBS TO EXTREME COUNTERCLOCKWISE POSITIONS. MATCHMARK KNOBS TO CONTROL CHASSIS. UPON REASSEMBLY, TURN CONTROL KNOB MOUNTING SHAFTS TO EXTREME COUNTERCLOCKWISE POSITIONS. MOUNT KNOBS ON SHAFTS SO THAT MATCHMARKS ARE ALINED. THIS PROCEDURE ASSURES CONTROL KNOBS ARE CORRECTLY POSITIONED FOR STARTING, OPERATING, AND STOPPING UNIT.

NOTE: EACH CIRCULAR CONTROL KNOB IS MOUNTED BY 2 SETSCREWS.

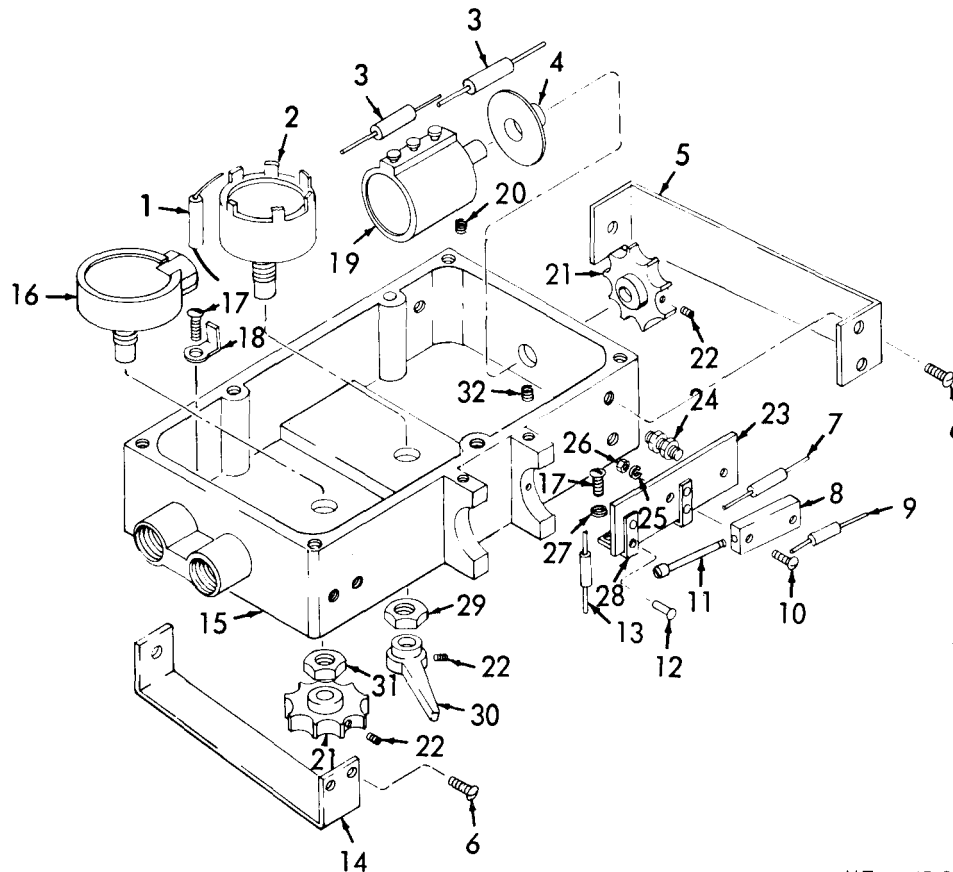

ME 6665-202-13/6-5

- | | |
|-----------------------------------|---------------------------------------|
| 1 Fixed resistor (2 k ohm) R5 | 17 Machine screw |
| 2 Control switch | 18 Terminal lug |
| 3 Fixed resistor (82 hm) R3 & R4 | 19 Variable resistor (500 ohm max) R2 |
| 4 Boot | 20 Insert |
| 5 Knob cover | 21 Knob |
| 6 Machine screw | 22 Setscrew |
| 7 Resistor (4.3 k ohm) R8 | 23 Terminal board |
| 8 Variable resistor (2k ohm) R6* | 24 Terminal |
| 9 Resistor (3.01 k ohm) R7* | 25 Lockwasher |
| 10 Machine screw | 26 Nut |
| 11 Screw | 27 Lockwasher |
| 12 Solid rivet | 28 Terminal board bracket |
| 13 Resistor (6 ohm) R9 | 29 Nut |
| 14 Knob cover | 30 Knob |
| 15 Control chassis | 31 Nut |
| 16 Variable resistor (1 k ohm) R1 | 32 Insert |

*Values given are for Polan Models P-153 and P-158. R6 is 5 k ohms and R7 is 2.21 k ohms in OTP MD-M.

Figure 6-5. Control box, disassembly and reassembly.

rotated, the resistor is defective and must be replaced. Test total resistance with a Whetstone Bridge. Disconnect all connections on end terminal of variable resistor (8) or slider terminal. Test resistor by connecting multimeter to slider terminal and terminal of resistor marked CCW. Rotate shaft and resistance should vary from 0 to 525 ohms. Connect multimeter to slider terminal and terminal marked CW, again rotate shaft and resistance should vary from 0 to 525 ohms.

6-5. Short Handle, Detector Head, and Balance Coil

a. Disassembly. Disassemble the short handle, detector head, and balance coil in the order of numerical sequence as illustrated by figure 6-6.

NOTE

Observe location of electrical leads on balance coil and clearly tag them before disconnecting to insure proper connection upon reassembly.

b. Cleaning, Inspection, and Repair.

(1) Wipe the detector head and short handle with a clean cloth slightly dampened with an approved cleaning solvent and dry thoroughly.

(2) Wipe any accumulation of dirt or moisture from the balance coil with a clean, dry cloth.

CAUTION

Be careful of type of cleaning solvent that is used on the equipment. The components are constructed of plastic and will be damaged if they are cleaned with some types of solvent. Make sure a suitable solvent that is approved for plastic is used when cleaning plastic components.

(3) Inspect the detector head for breaks, cracks, damaged threaded areas, corroded electrical leads, or other defects.

(4) Inspect the balance coil for breaks, cracks, defective seals, corroded or broken electrical leads, or other damage,

(5) Inspect the handle for breaks, cracks, damaged threaded areas, or other defects.

(6) Inspect the screws, bushings, washers, nut and adapter for chips, cracks, damaged threaded areas, or other defects.

(7) Replace a damaged or defective part as necessary.

c. Testing.

(1) *Transmitter coil.* Test the transmitter coils in the detector head by placing the meter

probes on 3 and 4 terminals of coils. The approximate resistance reading should be 2.6 to 2.8 ohms. If resistance readings are above or below 2.6 to 2.8 ohms, transmitter coil could be defective and detector head may have to be replaced.

(2) *Receiver coil.* Test the receiver coil in the detector head by placing the meter probes on 6 and 1 terminals of coils. Resistance should read 40 to 50 ohms. If resistance readings are above or below 40 to 50 ohms, coils are defective and detector head should be replaced.

d. Reassembly. Reassemble the short handle, detector head, and balance coil in the reverse order of numerical sequence as illustrated in figure 6-6.

6-6. Wiring

a. Cleaning.

(1) Wipe the wires with a cloth dampened slightly with an approved cleaning solvent and dry thoroughly.

(2) Clean corrosion from terminals with a brush or an approved corrosion remover.

b. Inspection.

(1) Inspect the insulation for cracks, fraying, and deterioration. Pay special attention to areas where wires pass through holes and over rough or sharp edges. Wrap cracked or frayed area with an approved electrical tape. Replace defective wires.

(2) Inspect wire terminals for cracks, splits, corrosion, and insecure mounting. Replace a defective terminal.

c. Testing. To test a wire for continuity, disconnect one end of the wire from the component to which it is attached. Touch the probes of a multimeter, set on the lowest ohm scale, to each end of the wire. The multimeter should indicate continuity. Replace a wire that does not show continuity.

d. Repair.

(1) If a broken wire is accessible, remove sufficient insulation from each side of the break to allow a good connection to the bared ends by twisting them together. Solder the connection and wrap it with electrical tape. Do not leave a bare connection exposed.

CAUTION

Do not use acid-core solder when performing maintenance on the detector set. Acidic action can erode circuit components, resulting in a defective or inop-

erative detector set. Use rosincore solder when soldering any connection.

(2) If a wire is broken from a terminal connector, replace the connector.

(3) If a break in a wire is in accessible, disconnect both ends of the wire and connect a new wire of the same gage and insulation to the proper terminals. Properly tag both ends of all replacement wires. Let the new wire follow the same path as the old as far as practicable, and in any event make sure that it does not interfere with normal operation of the equipment.

6-7. Case Latches

a. *Removal.* The top and bottom case latch and keepers may be removed by drilling or chiseling. If they are removed by drilling, make sure that you first center punch the rivet. Use a 1/8" drill and only drill deep enough to remove the head of the rivet. Use pliers to remove the rest of the rivet.

b. *Installation.* Make sure that all remnants of the old rivets are removed. Use blind rivets to fasten both catch and latch

6-8. Carrying Case (fig. 6-5.1)

a. *Cleaning.*

- (1) Wipe case (1) exterior with a dampened cloth.
- (2) Remove dirt and grime accumulation from pressure release valve (10).

b. *Inspection.*

- (1) Inspect pressure relief valve (10), sealing washer (11) and rivnut (12) for damage and proper operation.
- (2) Inspect catch (4) and strike (8) for damage and proper operation.
- (3) Inspect carrying handle (6) for serviceability.
- (4) Inspect gasket (7) for dry rot and serviceability.
- (5) Inspect cover insert (2) and base insert (9) for deformation.

c. *Repair.*

CAUTION

When removing moving attaching hardware, exercise extreme care while drilling or chiseling to prevent damage to case exterior.

(1) Catch, strike or handle removal.

(a) If latches or handle are welded onto case, remove by chiseling. If latches or handle are attached by rivets, use drill bit large enough to drill out rivet head only. Remove remainder of rivet with pliers.

(b) Remove damaged component and discard.

(c) Refinish surface area by sanding and spot painting

(2) Installation.

NOTE

Manufacturer's replacement catch will have a butt plate pre-assembled to catch for welding purposes. Catch ordered with MS part number may be used with rivets.

Position catch or handle and secure with rivets or by welding.

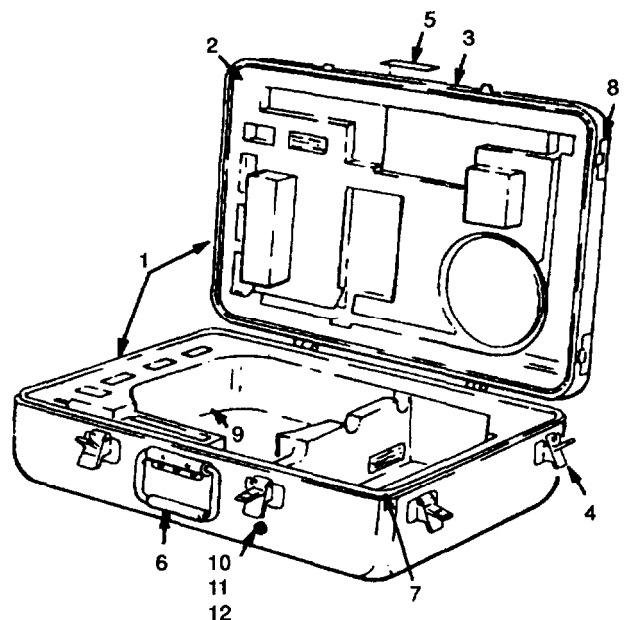
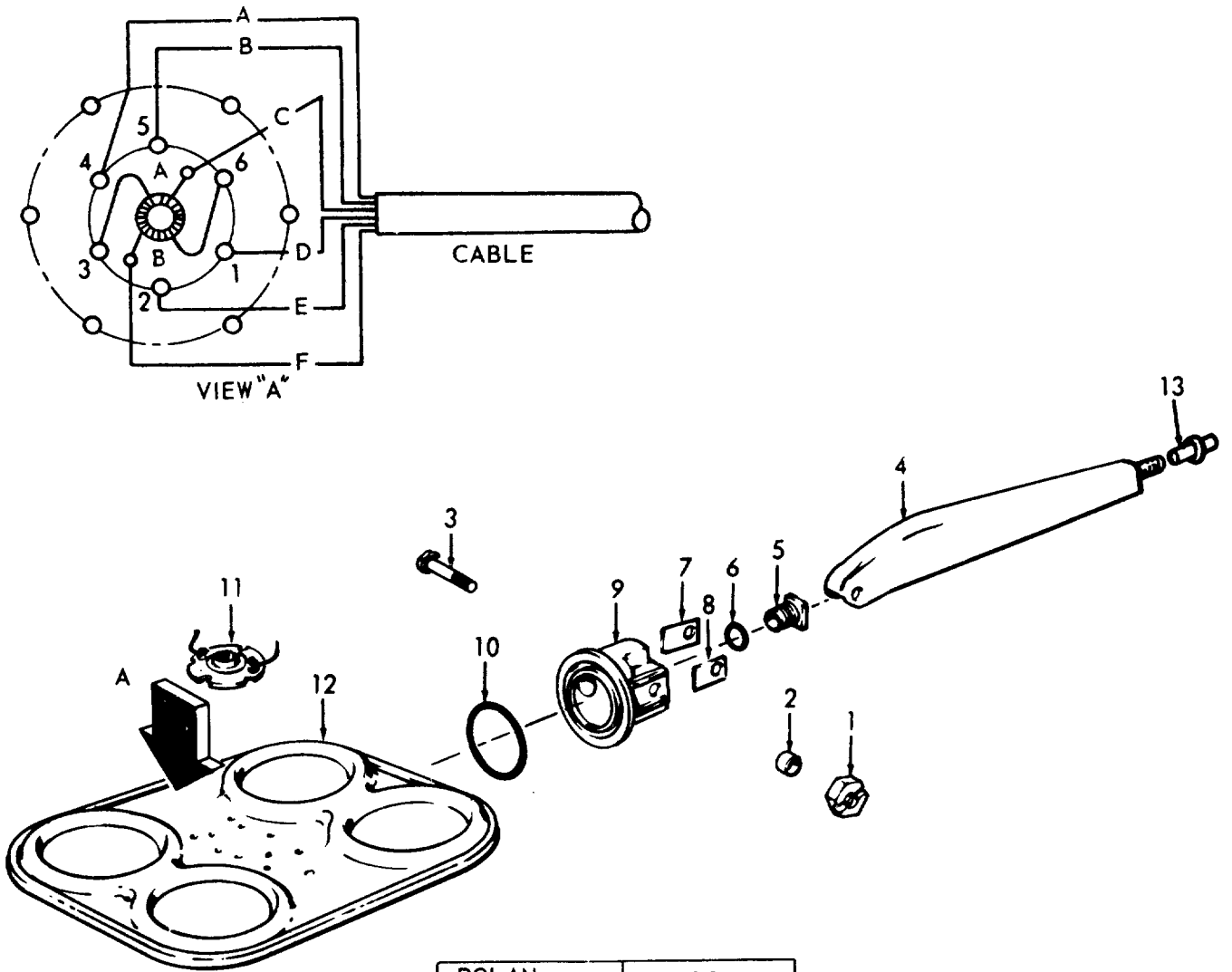

Figure 6-5.1. Carrying Case



		LEGEND	
POLAN MODELS P-153, P-158, AND P-190	OREGON TEXTRON MODEL MD-M	COLOR	FUNCTION
F	A	Red and White	Input
B	B	Shielded Black	Common
C	C	Orange and White	Output
D	D	Brown and White	Output
E	E	Shielded Black	Common
A	F	Black and White	Input

ME 6665-202-13/6-6

- 1 Nut
- 2 Adapter
- 3 Bolt
- 4 Handle
- 5 Bushing
- 6 Packing
- 7 Washer

- 8 Washer
- 9 Cap assembly
- 10 Packing
- 11 Balance coil
- 12 Detector head assembly
- 13 Strain relief

Figure 6-6. Short handle, detector head, and balance coil disassembly and reassembly.

APPENDIX A**REFERENCES**

A-1. Maintenance

- TM 5-6665-202-23P Organizational, Direct Support and General Support and Depot Maintenance Repair Parts and Special Tools Lists. Detecting Set, Mine
- TM 38-750 The Army Maintenance Management System (TAMMS)

A-2. Shipment and Storage

- TM 740-90-1 Administrative Storage of Equipment
- TM 740-244-3 Procedures for Destruction of Equipment to Prevent Enemy Use

Section II. INTEGRAL COMPONENTS OF END ITEM

(1) ILLUSTRATION		(2) NATIONAL STOCK NUMBER	(3) PART NO. & FSCM	(4) DESCRIPTION	(5) LOCATION	(6) USABLE ON CODE	(7) QTY. REQD.	(8) QUANTITY			
(a) FIGURE NO.	(b) ITEM NO.							RCVD	DATE	DATE	DATE
1-1		6665-00-996-0575	13207E9941 (97403)	Adapter: Battery Case Assy			1				
1-1		6665-00-996-7132	13200E2808 (97403)	Bag (cover): Assy; Receiver-Transmitter			1				
1-1		6665-00-991-0022	13200E2775 (97403)	Oscillator (Red)			1				
1-1		6665-00-991-0020	13200E2752 (97403)	Variometer (Black)			1				
1-1		6665-00-991-0019	132002735 (97403)	Amplifier Input			1				
1-1		6665-00-402-4845	13218E8074 (97403)	Amplifier Output (Yellow with black stripe)			1				
1-1		6185-00-961-3603	SCBA1389U (80063)	Battery: Mercury Dry			1				

Section III. BASIC ISSUE ITEMS

(1) ILLUSTRATION		(2) NATIONAL STOCK NUMBER	(3) PART NO. & FSCM	(4) DESCRIPTION	(5) LOCATION	(6) USABLE ON CODE	(7) QTY. REQD.	(8) QUANTITY			
(a) FIGURE NO.	(b) ITEM NO.							RCVD	DATE	DATE	DATE
1-1		6665-00-996-7134	13200E5310 (97403)	Block Assy: Phasing			1				
				DA MANUAL: TM 5-6665-202-13 TM 5-6665-202-23P			1				

APPENDIX C

MAINTENANCE ALLOCATION CHART

Section I. INTRODUCTION

C-1. General

a. This section provides a general explanation of all maintenance and repair functions authorized at various maintenance levels.

b. Section II designates overall responsibility for the performance of maintenance functions on the identified end item or component. The implementation of the maintenance functions upon the end item or component will be consistent with the assigned maintenance functions.

c. Section III lists the special tools and test equipment required for each maintenance function as referenced from section II.

d. Section IV contains supplemental instructions or explanatory notes required for a particular maintenance function.

C-2. Explanation of Columns in Section II

a. *Group Number, Column (1).* The assembly group number is a numerical group assigned to each assembly. The assembly groups are listed on the MAC in disassembly sequence beginning with the first assembly removed in a top down disassembly sequence.

b. *Assembly Group, Column (2).* This column contains a brief description of the components of each assembly group.

c. *Maintenance Functions, Column (3).* This column lists the various maintenance functions (A through K). The upper case letter placed in the appropriate column indicates the lowest maintenance level authorized to perform these functions. The symbol designations for the various maintenance levels are as follows:

- C-Operator or crew
- O-Organizational maintenance
- F-Direct support maintenance
- H-General support maintenance
- D-Depot maintenance

The maintenance functions are defined as follows:

A-Inspect: To determine serviceability of an item by comparing its physical, mechanical, and electrical characteristics with established standards.

B-Test: To verify serviceability and to detect electrical or mechanical failure by use of test equipment.

C-Service: To clean, to preserve, to charge, and to add fuel, lubricants, cooling agents, and air. (If it is desired that elements, such as painting and lubricating, be defined separately, they may be so listed).

D-Adjust: To rectify to the extent necessary to bring into proper operating range.

E-Aline: To adjust specified variable elements of an item to bring to optimum performance.

F-Calibrate: To determine the corrections to be made in the readings of instruments or test equipment used in precise measurement. Consists of the comparison of two instruments, one of which is a certified standard of known accuracy, to detect and adjust any discrepancy in the accuracy of the instrument being compared with the certified standard.

G-Install: To set up for use in an operational environment such as an emplacement, site, or vehicle.

H-Replace: To replace unserviceable items with serviceable like items.

I-Repair: Those maintenance operations necessary to restore an item to serviceable condition through correction of material damage or a specific failure. Repair may be accomplished at each level of maintenance.

J-Overhaul: Normally, the highest degree of maintenance performed by the Army in order to minimize time work is in process consistent with quality and economy of operation. It consists of that maintenance necessary to restore an item to completely serviceable condition as prescribed by maintenance standards in technical publications

for each item of equipment. Overhaul normally does not return an item to like new, zero mileage, or zero hour condition.

K - Rebuild: The highest degree of materiel maintenance. It consists of restoring equipment as nearly as possible to new condition in accordance with original manufacturing standards. Rebuild is performed only when required by operational considerations or other paramount factors and then only at the depot maintenance level. Rebuild reduces to zero the hours or miles the equipment, or component thereof, has been in use.

d. Tools and Equipment, Column (4). This column is provided for referencing by code the special tools and test equipment (sec III), required to perform the maintenance functions (sec II).

e. Remarks, Column (5). This column is provided for referencing by code the remarks (sec. IV) pertinent to the maintenance functions.

C-3. Explanation of Columns in Section III

a. Reference Code. This column consists of a number and a letter separated by a dash. The

number references the T & TE requirements listed in section II. The letter represents the specific maintenance function the item is to be used with in columns A through K of Section II.

b. Maintenance Level. This column shows the lowest level of maintenance authorized to use the special tool or test equipment.

c. Nomenclature. This column lists the name or identification of the tool or test equipment.

d. Tool Number. This column lists the manufacturer's code and part number, or Federal stock number of tool or test equipment.

C-4. Explanation of Columns in Section IV

a. Reference Code. This column consists of two letters separated by a dash (entered from COL (5) of sec. II). The first letter references alpha sequence in column 5 and the second letter references a maintenance function, column (3), A through K.

b. Remarks. This column lists information pertinent to the maintenance function to be performed (as indicated in sec. II).

Section II. Maintenance Allocation Chart

(1) Group No.	(2) Assembly Group	(3) Maintenance functions										(4) Tools and equipment	(5) Remarks	
		A	B	C	D	E	F	G	H	I	J			K
		Inspect	Test	Service	Adjust	Align	Calibrate	Install	Replace	Repair	Overhaul	Rebuild		
01	BODY ACCESSORY ITEMS													
	Carrying cases -----	C	--	C	--	--	--	--	O	O	--	--	-----	----A
	Adapter, battery -----	C	O	O	--	--	--	--	O	F	F	--	-----	----B
02	PRECISION INSTRUMENTS AND SYSTEMS, ELECTRONIC													
	Mechanical Precision Parts													
	Receiver and transmitter assembly -----	C	--	C	--	--	--	--	F	O	F	--	-----	----C
	Batteries -----	C	O	--	--	--	--	--	O	--	--	--	-----	----D
	Modules -----		F	--	--	--	--	--	O	--	--	--	1	
	Circuit components and capacitors, and resistors -----		F	--	--	--	--	--	F					
	Controls, Indicators, and Special Components													
	Headset assy, electrical -----	C	F	C	--	--	--	--	F	F				
	Switches, control box -----		F	--	--	--	--	--	F					

(1) Group No.	(2) Assembly Group	(3) Maintenance functions											(4) Tools and equipment	(5) Remarks	
		A	B	C	D	E	F	G	H	I	J	K			
		Inspect	Test	Service	Adjust	Align	Calibrate	Install	Replace	Repair	Overhaul	Rebuild			
	Detector head and balance coil assembly Miscellaneous Wiring and Fittings Wiring harness, branched Mounted Connecting Devices Board, printed Connector strip assembly	C	F	C	-	-	-	-	F	F					
		-	-	-	-	-	-	-	F	F					
		-	-	-	-	-	-	-	F	F					
		-	-	-	-	-	-	-	F	F					

Section III. SPECIAL TOOL AND SPECIAL TEST EQUIPMENT REQUIREMENTS

Reference code	Maintenance category	Nomenclature	Tool number
1-B	F	Voltmeter	6625-00-727-4706
2-B	F	Test Lead	6625-01-022-8217
3-B	F	Phasing Fixture	6665-01-150-9855

Section IV. REMARKS

Reference code	Remarks
A-C B-B C-I D-B	<p>Clean.</p> <p>Test assembly for continuity and replace "O" rings.</p> <p>Replace battery and modules only, all other repair is accomplished at Direct Support Maintenance.</p> <p>Test Battery. Test is accomplished with battery installed and mine detector turned on. The receiver transmitter assembly removed from its housing. A voltmeter is used to determine battery voltage. Connect the ground or negative lead of the voltmeter to pin number 1 on terminal board, connect the positive lead or (plus) lead of the meter to the receiver transmitter assembly chassis. If battery voltage is below 7.0 volts, it should be replaced.</p>

INDEX

	Paragraph	Page
A		
Adapter, battery (inspection)	3-7	3-2
Adapter, battery (repair)	6-1	6-1
B		
Balance coil (repair)	6-5	6-8
Battery adapter inspection	3-7	3-2
Battery adapter (org. maintenance)	4-10	4-3
Battery adapter (repair)	6-1	6-1
Battery inspection	3-9	3-2
C		
Carrying case (org. maintenance)	4-9	4-3
Case (operator's maintenance)	3-6	3-2
Chassis (receiver and transmitter)	6-2	6-1
Controls and instruments	2-6	2-3
Control box (direct support maintenance)	5-7	5-2
Control box (repair)	6-4	6-6
D		
Demolition and Administrative Storage	1-2	1-1
Description	1-5	1-1
Detector head (repair)	6-5	6-8
Detector head and balance coil assembly (direct support maintenance)	5-8	5-2
Detector head and balance coil assembly (operator's maintenance)	3-11	3-3
Detector sensitivity test	6-2	6-1
Differences between models	1-6	1-1
Dismantling for movement	2-3	2-2
G		
General:		
Controls (operator's)	2-5	2-3
Maintenance (operator's)	3-5	3-2
Operation under usual conditions	2-7	2-3
Preventive maintenance checks and services (daily)	3-1	3-1
Preventive maintenance checks and services (monthly)	4-5	4-1
Troubleshooting (direct support maintenance)	5-4	5-1
Troubleshooting (operator's maintenance)	3-3	3-2
Troubleshooting (organizational maintenance)	4-7	4-2
H		
Headset assembly (operator's maintenance)	3-10	3-2
Headset assembly (repair)	6-3	6-5
Headset (direct support maintenance)	5-6	5-2
I		
Identification and tabulated data	1-7	1-1
Inspecting and servicing the equipment (operator)	2-1	2-1
Inspecting and servicing the equipment (organizational maintenance)	4-1	4-1
Installation	4-2	4-1
Installation and setting up instructions	2-2	2-1

	Paragraph	Page
M		
Maintenance forms and records -----	1-3	1-1
Maintenance repair parts (direct support maintenance) -----	5-3	5-1
Maintenance repair parts (organizational maintenance) -----	4-4	4-1
Mine detecting set case -----	3-6	3-2
Mine detecting set maintenance -----	3-5	3-2
Mine detecting set operation -----	2-10	2-4
Module phasing -----	6-2	6-1
Modules -----	5-9	5-2
O		
Operation in dusty or sandy areas -----	2-12	2-9
Operation in salt water areas -----	2-14	2-4
Operation in temperatures below 70°F -----	2-11	2-9
Operation under rainy or humid conditions -----	2-13	2-9
Operator's preventive maintenance checks and services -----	3-1	3-1
P		
Preventive maintenance checks and services (daily) -----	3-2	3-1
Preventive maintenance checks and services (monthly) -----	4-6	4-2
R		
Receiver and transmitter assembly (operator's maintenance) -----	3-8	3-2
Receiver and transmitter assembly (organizational maintenance) -----	4-11	4-3
Receiver and transmitter assembly (repair) -----	6-2	6-1
Receiver coil (repair) -----	6-5	6-8
Reinstallation after movement -----	2-4	2-3
Reporting of errors -----	1-4	1-1
S		
Scope -----	1-1	1-1
Short handle, detector head and balance coil -----	6-5	6-8
Special tools and equipment (direct support maintenance) -----	5-2	5-1
Special tools and equipment (organizational maintenance) -----	4-3	4-1
Starting -----	2-8	2-3
Stopping -----	2-9	2-4
T		
Tabulated data -----	1-7	1-1
Terminal board (repair) -----	6-2	6-1
Tools and equipment -----	5-1	5-1
Transmitter coil (repair) -----	6-5	6-8
Transmitter (operator's maintenance) -----	3-8	3-2
Transmitter (organizational maintenance) -----	4-11	4-3
Troubleshooting (direct support maintenance) -----	5-5	5-1
Troubleshooting (operator's) -----	3-4	3-2
Troubleshooting (organizational maintenance) -----	4-8	4-2
W		
Wiring -----	6-6	6-8

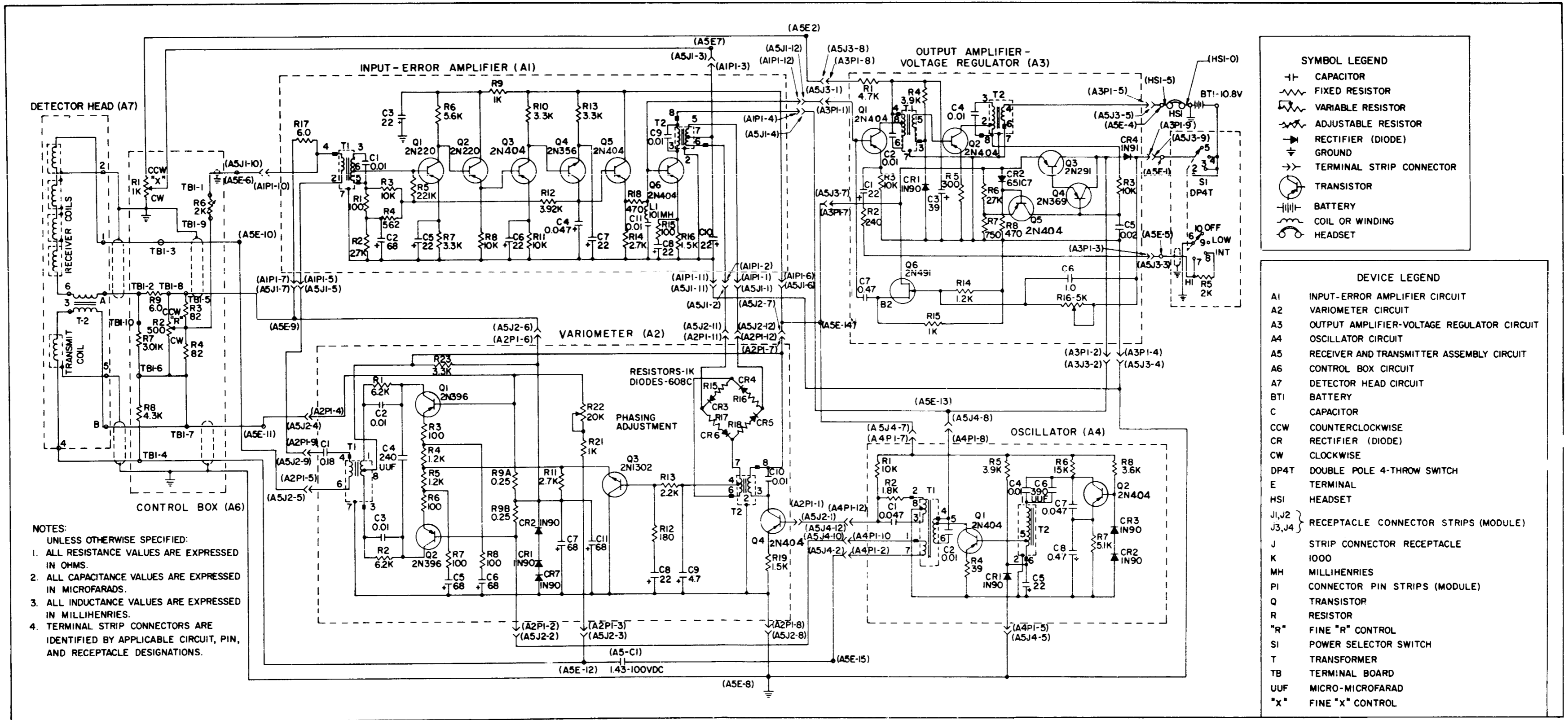

NOTES:
 UNLESS OTHERWISE SPECIFIED:
 1. ALL RESISTANCE VALUES ARE EXPRESSED IN OHMS.
 2. ALL CAPACITANCE VALUES ARE EXPRESSED IN MICROFARADS.
 3. ALL INDUCTANCE VALUES ARE EXPRESSED IN MILLIHENRIES.
 4. TERMINAL STRIP CONNECTORS ARE IDENTIFIED BY APPLICABLE CIRCUIT, PIN, AND RECEPTACLE DESIGNATIONS.

SYMBOL LEGEND	
	CAPACITOR
	FIXED RESISTOR
	VARIABLE RESISTOR
	ADJUSTABLE RESISTOR
	RECTIFIER (DIODE)
	GROUND
	TERMINAL STRIP CONNECTOR
	TRANSISTOR
	BATTERY
	COIL OR WINDING
	HEADSET

DEVICE LEGEND	
A1	INPUT-ERROR AMPLIFIER CIRCUIT
A2	VARIOMETER CIRCUIT
A3	OUTPUT AMPLIFIER-VOLTAGE REGULATOR CIRCUIT
A4	OSCILLATOR CIRCUIT
A5	RECEIVER AND TRANSMITTER ASSEMBLY CIRCUIT
A6	CONTROL BOX CIRCUIT
A7	DETECTOR HEAD CIRCUIT
BT1	BATTERY
C	CAPACITOR
CCW	COUNTERCLOCKWISE
CR	RECTIFIER (DIODE)
CW	CLOCKWISE
DP4T	DOUBLE POLE 4-THROW SWITCH
E	TERMINAL
HSI	HEADSET
J1, J2	RECEPTACLE CONNECTOR STRIPS (MODULE)
J3, J4	
J	STRIP CONNECTOR RECEPTACLE
K	1000
MH	MILLIHENRIES
PI	CONNECTOR PIN STRIPS (MODULE)
Q	TRANSISTOR
R	RESISTOR
"R"	FINE "R" CONTROL
SI	POWER SELECTOR SWITCH
T	TRANSFORMER
TB	TERMINAL BOARD
UUF	MICRO-MICROFARAD
"X"	FINE "X" CONTROL

FO-1. Electrical schematic diagram.

Figure FO-1.

By Order of the Secretary of the Army:

W. C. WESTMORELAND,
General, United States Army,
Chief of Staff.

Official:

VERNE L. BOWERS
Major General, United States Army,
The Adjutant General.

Distribution:

To be distributed in accordance with DA Form 12-25A (qty rqr Block #133), Operator requirements for Land Mine Detection.

RECOMMENDED CHANGES TO EQUIPMENT TECHNICAL PUBLICATIONS



THEN...JOT DOWN THE DOPE ABOUT IT ON THIS FORM. CAREFULLY TEAR IT OUT, FOLD IT AND DROP IT IN THE MAIL.

SOMETHING WRONG WITH PUBLICATION

FROM: (PRINT YOUR UNIT'S COMPLETE ADDRESS)

DATE SENT

PUBLICATION NUMBER

PUBLICATION DATE

PUBLICATION TITLE

BE EXACT PIN-POINT WHERE IT IS

PAGE NO.

PARA-GRAPH

FIGURE NO.

TABLE NO.

IN THIS SPACE, TELL WHAT IS WRONG AND WHAT SHOULD BE DONE ABOUT IT.

TEAR ALONG PERFORATED LINE

PRINTED NAME, GRADE OR TITLE AND TELEPHONE NUMBER

SIGN HERE

The Metric System and Equivalents

Linear Measure

1 centimeter = 10 millimeters = .39 inch
 1 decimeter = 10 centimeters = 3.94 inches
 1 meter = 10 decimeters = 39.37 inches
 1 dekameter = 10 meters = 32.8 feet
 1 hectometer = 10 dekameters = 328.08 feet
 1 kilometer = 10 hectometers = 3,280.8 feet

Weights

1 centigram = 10 milligrams = .15 grain
 1 decigram = 10 centigrams = 1.54 grains
 1 gram = 10 decigrams = .035 ounce
 1 dekagram = 10 grams = .35 ounce
 1 hectogram = 10 dekagrams = 3.52 ounces
 1 kilogram = 10 hectograms = 2.2 pounds
 1 quintal = 100 kilograms = 220.46 pounds
 1 metric ton = 10 quintals = 1.1 short tons

Liquid Measure

1 centiliter = 10 milliliters = .34 fl. ounce
 1 deciliter = 10 centiliters = 3.38 fl. ounces
 1 liter = 10 deciliters = 33.81 fl. ounces
 1 dekaliter = 10 liters = 2.64 gallons
 1 hectoliter = 10 dekaliters = 26.42 gallons
 1 kiloliter = 10 hectoliters = 264.18 gallons

Square Measure

1 sq. centimeter = 100 sq. millimeters = .155 sq. inch
 1 sq. decimeter = 100 sq. centimeters = 15.5 sq. inches
 1 sq. meter (centare) = 100 sq. decimeters = 10.76 sq. feet
 1 sq. dekameter (are) = 100 sq. meters = 1,076.4 sq. feet
 1 sq. hectometer (hectare) = 100 sq. dekameters = 2.47 acres
 1 sq. kilometer = 100 sq. hectometers = .386 sq. mile

Cubic Measure

1 cu. centimeter = 1000 cu. millimeters = .06 cu. inch
 1 cu. decimeter = 1000 cu. centimeters = 61.02 cu. inches
 1 cu. meter = 1000 cu. decimeters = 35.31 cu. feet

Approximate Conversion Factors

To change	To	Multiply by	To change	To	Multiply by
inches	centimeters	2.540	ounce-inches	newton-meters	.007062
feet	meters	.305	centimeters	inches	.394
yards	meters	.914	meters	feet	3.280
miles	kilometers	1.609	meters	yards	1.094
square inches	square centimeters	6.451	kilometers	miles	.621
square feet	square meters	.093	square centimeters	square inches	.155
square yards	square meters	.836	square meters	square feet	10.764
square miles	square kilometers	2.590	square meters	square yards	1.196
acres	square hectometers	.405	square kilometers	square miles	.386
cubic feet	cubic meters	.028	square hectometers	acres	2.471
cubic yards	cubic meters	.765	cubic meters	cubic feet	35.315
fluid ounces	milliliters	29.573	cubic meters	cubic yards	1.308
pints	liters	.473	milliliters	fluid ounces	.034
quarts	liters	.946	liters	pints	2.113
gallons	liters	3.785	liters	quarts	1.057
ounces	grams	28.349	liters	gallons	.264
pounds	kilograms	.454	grams	ounces	.035
short tons	metric tons	.907	kilograms	pounds	2.205
pound-feet	newton-meters	1.356	metric tons	short tons	1.102
pound-inches	newton-meters	.11296			

Temperature (Exact)

°F	Fahrenheit	5/9 (after	Celsius	°C
	temperature	subtracting 32)	temperature	

PIN: 026247-004